



# HO-430x700/1000/1700 精密高速車床 HIGH SPEED PRECISION LATHE

## 特點：

- \* 床身以高級合金鑄鐵(FC-25)鑄造而成，鋼性強韌，床面永不變形。
- \* 主軸箱內部齒輪及心軸採用鉻鉬鋼，經滲碳熱處理，研磨而成。主軸採用三點式，以高精度滾筒軸承支持，鋼性特強。
- \* 齒輪箱為密封浸油式，變速方便迅速，可作英制、公制、徑節、模數四種螺紋之車製。
- \* 床護亦採用密封浸油式，縱橫進給與車削螺紋均有安全裝置，安全性提高。
- \* 尾座寬大，可耐重切削，鎖緊力特強，心軸押送時，不會產生滑脫現象。

## FEATURES :

- \* Machine body is made of high rigidity cast iron (FC 25) so that the slide ways will be durable and won't be transformed forever.
- \* Spindle and gears in spindle housing are all made of chrome molybdenum steel which are hardened and grounded. Spindle is supported by high precision roller bearings put three points on the spindle. So, its rigidity is higher.
- \* Gears of gear box are dipped with oil in a closed box making it easier and more convenient to change speeds. Can make threads such as imperial, metric, diametral, pitch and module.
- \* Apron is oil dipped, too. Cross and longitudinal feeding are all equipped with a safety device.
- \* Tailstock with bigger body can produce heavy duty cutting. Locks firmly to prevent from slipping when center feeding.



榮獲台中縣政府  
2006年績優廠商  
網址：[www.hungho.url.tw](http://www.hungho.url.tw)

**金手獎**

Was awarded Taichung County Excellent Firm Golden Hand Prize.



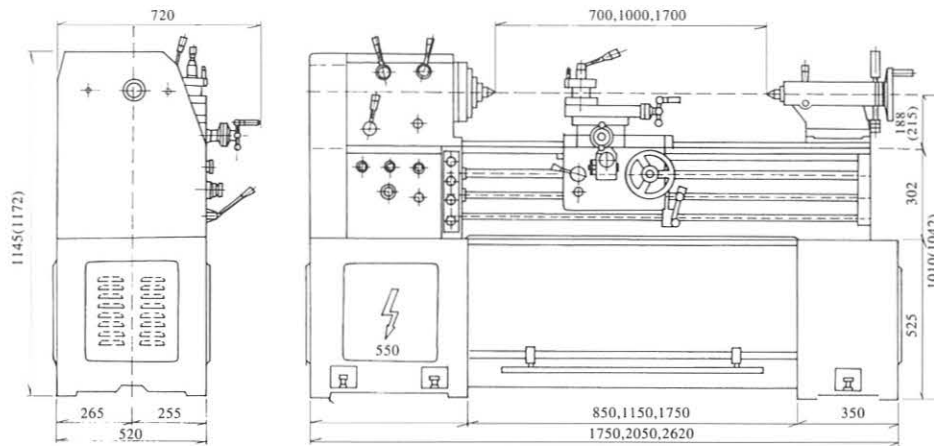

## 規格 SPECIFICATIONS :

		430×700	430×1000/1700
工作範圍 Capacity	中心至床面高度 Height of centers	215 [ 8" ]	
	床面上最大工作物直徑 Swing over bed	434 [ 17" ]	
	橫送台上最大工作物直徑 Swing over cross slide	270 [ 11" ]	
	凹口至面板寬度 Width between gap to faceplate	220 [ 9" ]	
	凹口上最大工作物直徑 Swing over gap	650 [ 26" ]	
	床面寬度 Width of bed	300 [ 12" ]	
主軸 Spindle	主軸孔徑及鼻端 Hole through spindle & spindle nose	54 [ A1 - 6 ]	
	主軸速度(8段) Spindle speeds (rpm)	70 - 1800	
	主軸頂心斜度 Center	MT4	
進給及車製 螺紋範圍 Feeds & Threads	縱橫進給量範圍(32段) Range of longitudinal/Cross feeds (32step)	0.06 - 0.83	
	英制螺紋(32段) Imperial threads (32 step)	4 - 56 TPI	
	公制螺紋(32段) Metric threads (32 step)	0.4 - 7 P	
複合刀架 Carriage	橫送面移動範圍 Travel of cross slide	270	
	刀架滑動移動範圍 Travel of top slide	130	
尾座 Tailstock	尾座心軸移動範圍 Travel of tailstock sleeve	165	
	尾座頂心斜度 Center of tailstock	MT4	
馬達 MOTORS	主軸馬達 Spindle drive motor	3HP	
機械體積及重量 MACHINE DIMENSIONS AND WEIGHT	佔用空間 (長×寬×高) KGSpace required (L×W×H)m/m	1750×750×1200	2050/2620×750×1200
	裝箱尺寸 (長×寬×高) Packing dimensions(L×W×H)m/m	1860×810×1520	2190/2690×810×1520
	淨重 (約) Net weight (approximate) KG	1000kg	1100/1300kg

### 標準附件 STANDARD ACCESSORIES:

自動進刀停止裝置	Automatic longitudinal feed stop device.
連接板	Drive Plate.....2 (7"/9"各一)
頂心	Center.....2
心軸套筒	Spindle Sleeve.....1
工具箱	Tool Box.....1
安裝固定片	Installation Blocks.....6
馬達	Motor.....3HP
中心架	Steady Rest.....1

### 特別附件 EXTRA ACCESSORIES:

三爪夾頭	3-Jaw Chuck
四爪夾頭	4-Jaw Chuck
冷卻泵浦	Coolant Pump
馬達	Motor.....5HP



## 宏宏精密有限公司

HUNG HUNG PRECISION CO., LTD.

公司：台中縣大雅鄉西寶村中正路金和巷1弄1號  
No. 1, Alley 1, Lane Jin He, Jung jeng Rd., Ta Ya Hsiang, Taichung Hsien, Taiwan, 428.

工廠：台中縣大雅鄉雅潭路106號  
No. 106, Ya-Tarn Road, Ta Ya Hsiang, Taichung Hsien, Taiwan, 428.

電話：04-25670833, 25672768

傳真：04-25662570

E-mail: hungho@ms34.hinet.net

## 總經銷 AGENT: