



More

[www.takisawa.com.tw](http://www.takisawa.com.tw)

Taiwan TAKISAWA Technology Co., Ltd.

No.505, Sec. 3, Yanping Rd., Pingzhen City,  
Taoyuan County 324, Taiwan.

TEL : (03)464-3166 FAX : (03)464-2614

No.89, Sec. 1, Meishi Rd., Yangmei City,  
Taoyuan County 326, Taiwan.

TEL : (03)481-3119 FAX : (03)481-3185

E-mail : [callcenter@takisawa.com.tw](mailto:callcenter@takisawa.com.tw)

Shanghai TAKISAWA Mechatronics Ltd.

No.1568, Yuanguo Road, Anting Town, Jiading  
District, Shanghai

TEL : (021)5956-2955 FAX : (021)5956-2956

**TAKISAWA**<sup>®</sup>  
TAIWAN

Distributor

2014.02

# LA-250/300 SERIES

**TAKISAWA**<sup>®</sup>  
TAIWAN

LA250[L]  
LA-250M[L]  
LA-250Y[L]  
LA-300

CNC  
LATHE



**BUILT TO JAPANESE QUALITY  
STANDARDS BY TAIWAN TAKISAWA.**



LA-250/300 series  
P.3



Spindle specifications  
P.6



Spindle output diagram  
P.6



Turret specifications  
Power chart for milling tool  
P.7



Machine dimensions  
Working ranges  
Interference diagrams  
P.9



Tooling system  
P.11



Specifications  
P.12



Standard and optional accessories  
P.13



## LA-250 SERIES

LA250[L] Turning  
LA-250M[L] Turning and Milling  
LA-250Y[L] Turning and Milling with Y axis



## LA-300

LA-300 Turning



# LA-250 | LA-300 Series

# LA

## 250/300 SERIES

### High Performance Model Range

- Modulized structure with optional C axis and Y axis.
- Box way design for all machining axes.
- Takisawa in-house turret and spindle featuring high rigidity and accuracy with easy maintenance.
- Minimum footprint, maximum working space.
- High productivity to investment cost ratio.



#### LA-250[L] Specifications

Max. swing	580 mm
Max. turning length	765[1165] mm
Max. turning diameter	450 mm
Max. bar work capacity	76(90) mm
Spindle speed	3000(3500) rpm
Chuck size	10"



#### LA-250Y[L] Specifications

Max. swing	580 mm
Max. turning length	746.5[1146.5] mm
Max. turning diameter	350 mm
Max. bar work capacity	75 mm
Spindle speed	3000(3500) rpm
Chuck size	10"



#### LA-250M[L] Specifications

Max. swing	580 mm
Max. turning length	734[1134] mm
Max. turning diameter	420 mm
Max. bar work capacity	75 mm
Spindle speed	3000(3500) rpm
Chuck size	10"



#### LA-300 Specifications

Max. swing	580 mm
Max. turning length	1150 mm
Max. turning diameter	450 mm
Max. bar work capacity	90 mm
Spindle speed	3000 rpm
Chuck size	12"(15")

※ Specifications are subject to change without notice.



# LA-250 | LA-300 Series



# Spindle output diagram

# LA

## 250/300 SERIES

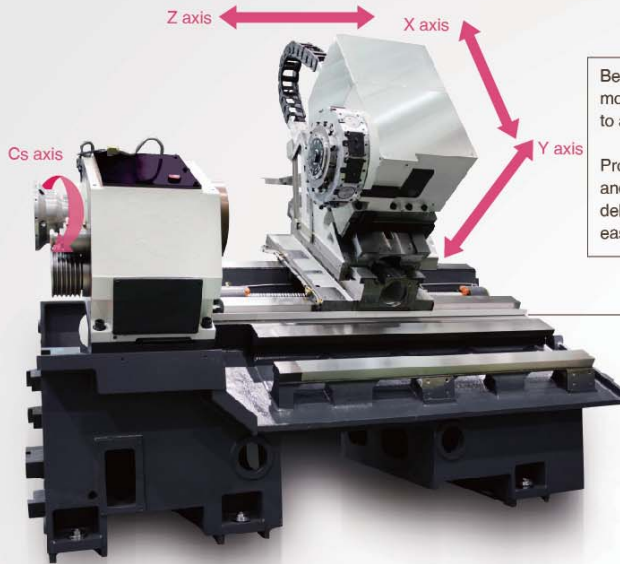

Bed surface hatchback integrally molded cradle with box way design to achieve high performance.

Provides smooth chip resistance and spacious space for clearing debris becomes convenient and easy.

### Travel & Feedrate

LA-250[L]	
X axis travel	255 mm
X axis rapid traverse rate	16 m/min
Z axis travel	800[1200] mm
Z axis rapid traverse rate	20 m/min

LA-250M[L]	
X axis travel	255 mm
X axis rapid traverse rate	16 m/min
Z axis travel	800[1200] mm
Z axis rapid traverse rate	20 m/min

LA-250Y[L]	
X axis travel	220 mm
X axis rapid traverse rate	16 m/min
Z axis travel	800[1200] mm
Z axis rapid traverse rate	20 m/min
Y axis travel	±50 mm
Y axis rapid traverse rate	8 m/min

LA-300	
X axis travel	255 mm
X axis rapid traverse rate	16 m/min
Z axis travel	1200 mm
Z axis rapid traverse rate	20 m/min

※ Specifications are subject to change without notice.

Standard  
Option

Powered by FANUC MOTOR for high stability & high accuracy.

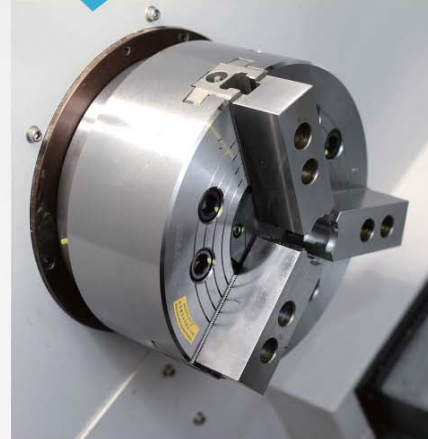
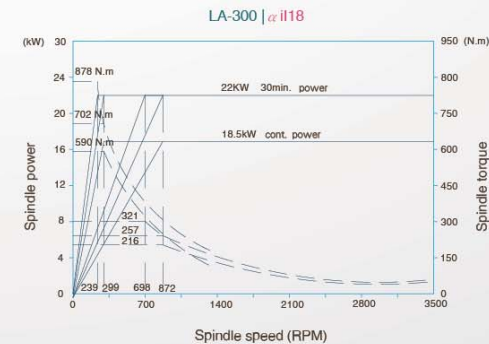
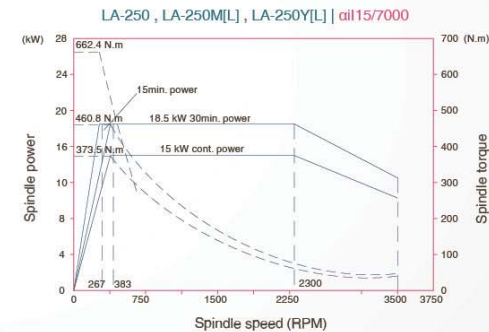
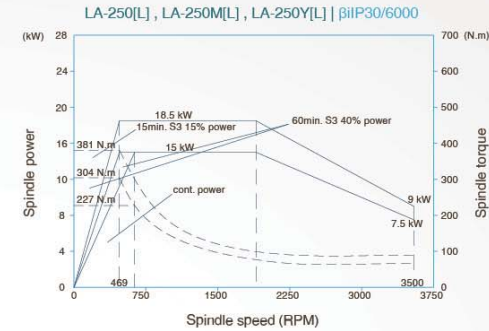

The spindle incorporates double rows of cylindrical bearings to improve the quality and accuracy of machining.



The LA series with C-axis positioning allows driven tool milling avoiding artifacts generated by compounding movement errors, giving higher accuracy with shorter process times and less effort.



## Turret specifications



The turret is designed for extreme rigidity through its wide and heavy build, inclusion of heavy duty oversized couplings and enhanced clamping pressure.



### Milling turret

LA-250M[L]  
 Motor 3.7/5.5 kW  
 Milling speed 4000 rpm  
 Live tool collet ER32

LA-250Y[L]  
 Motor 3.7/5.5 kW  
 Milling speed 4000 rpm  
 Live tool collet ER32

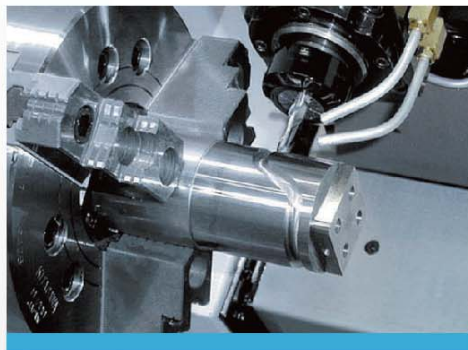

## Power chart of milling tool

LA-250M[L] · LA-250Y[L]

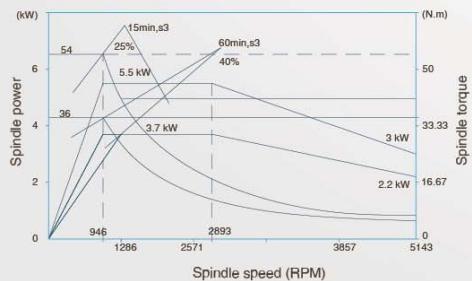

## Machine dimensions

# LA

### 250/300 SERIES

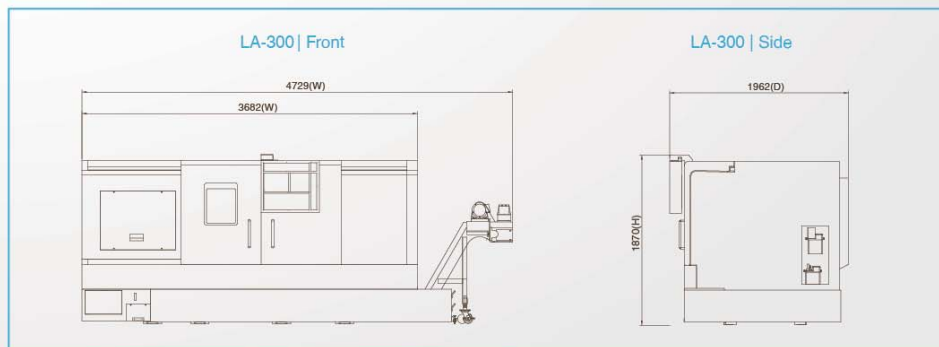
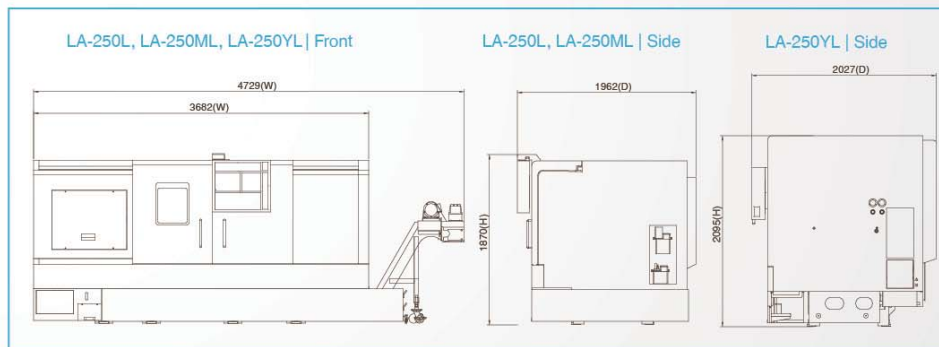
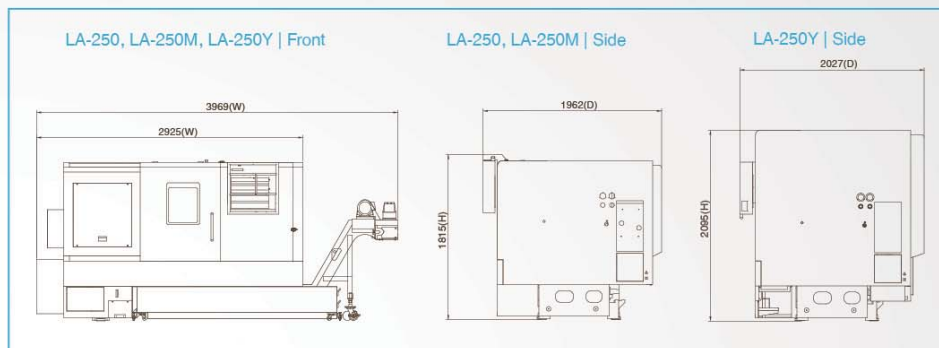



# Working range | Interference diagram

# LA

## 250/300 SERIES

### LA-300 Working Range

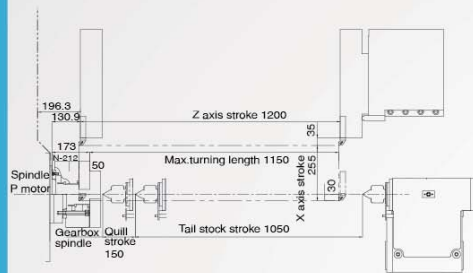

### LA-250[L] Working Range

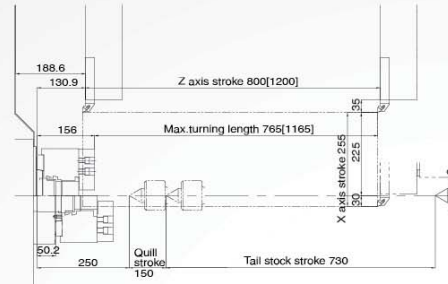

### LA-250M[L] Working Range

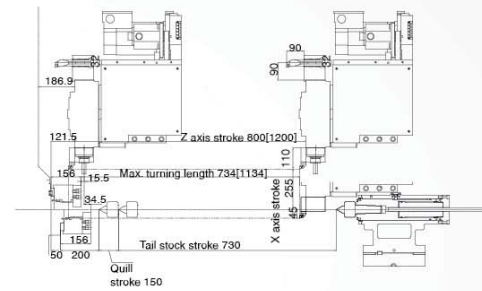

### LA-250Y[L] Working Range

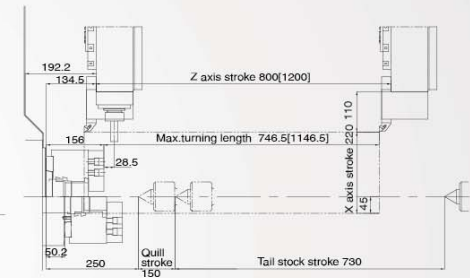

### LA-300 Interference Diagram (T10)

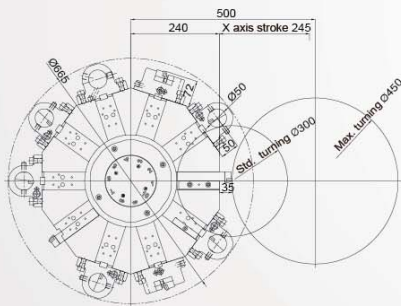

### LA-250[L] Interference Diagram (T10)

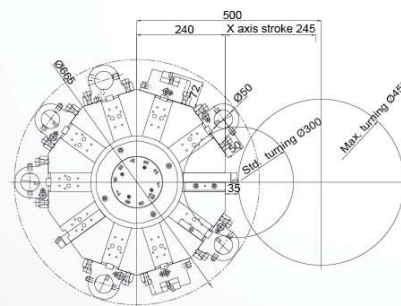

### LA-250M[L] Interference Diagram

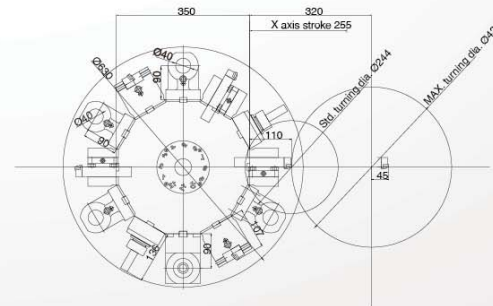

### LA-250Y[L] Interference Diagram

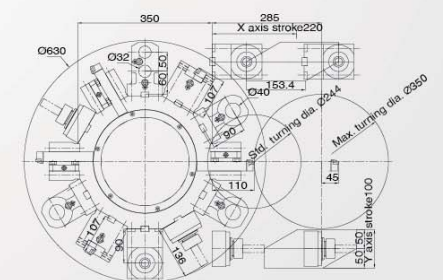

### LA-250[L] Interference Diagram (T12)

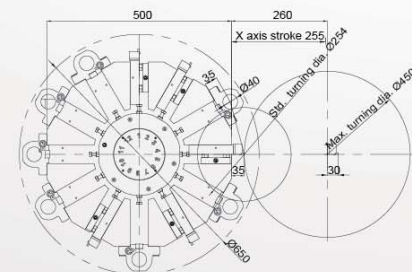



## Tooling system

LA-250[L] | LA-300

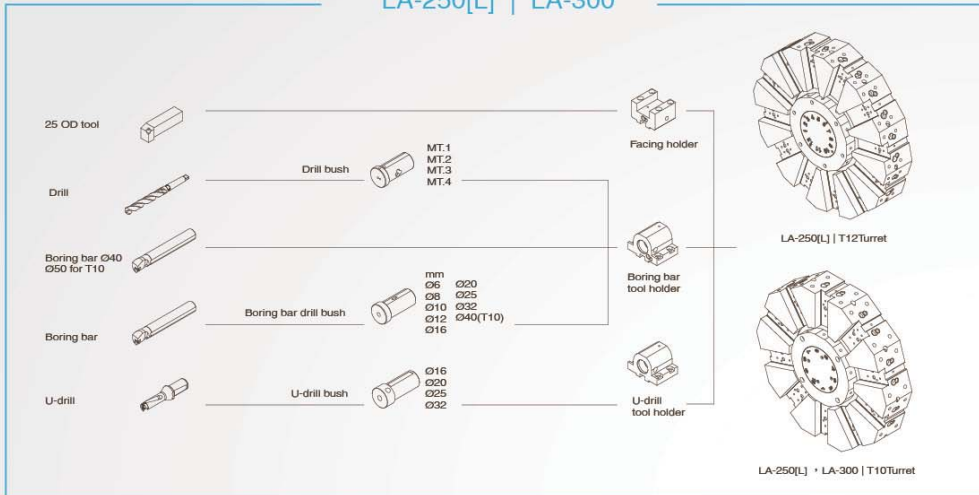

LA-250M[L] | LA-250Y[L]

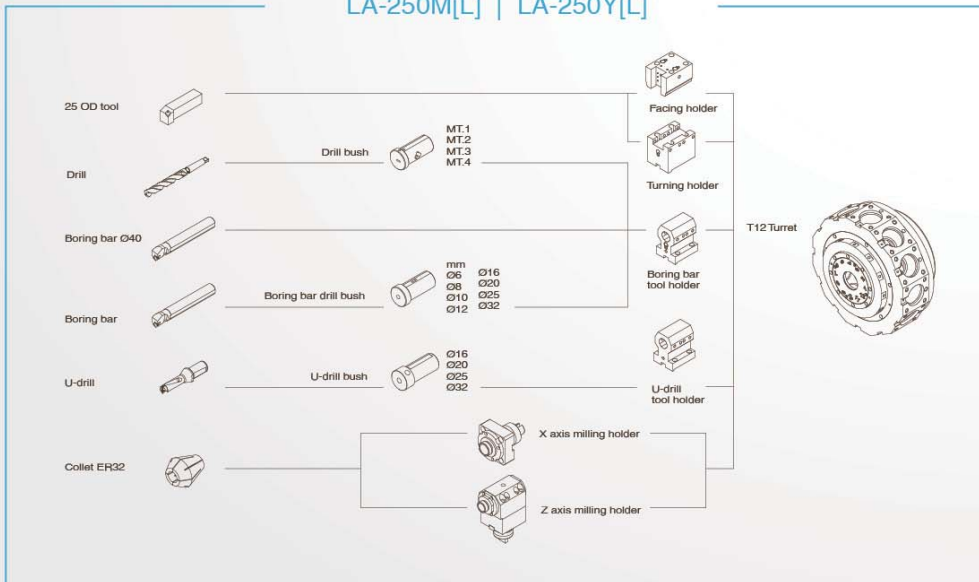

## Specifications

# LA

### 250/300 SERIES

Remark1 : ( ) Option  
Remark2 : M : Milling Y : Y axis

Item	Unit	LA-250[L]	LA-250M[L]	LA-250Y[L]	LA-300
<b>Capacity</b>					
Max. swing	mm	580	580	580	580
Std. turning diameter	mm	300(T10)   254(T12)	244	244	300(T10)   254(T12)
Max. turning diameter	mm	450	420	350	450
Max. turning length	mm	765[1165]	734	746.5[1146.5]	1150
Max. bar work capacity	mm	75(90)	75	75	90
<b>Travel</b>					
X axis travel	mm	255	255	220	255
Z axis travel	mm	800[1200]	800[1200]	800[1200]	1200
Y axis travel	mm	---	---	±50	---
<b>Spindle</b>					
Spindle speed	rpm	3000(3500)	3000(3500)	3000(3500)	3000
Chuck size		10"	10"	10"	12"(15")
Spindle nose		A2-8	A2-8	A2-8	A2-8
Through hole diameter	mm	86(102)	86	86	102
Bearing diameter	mm	120(140)	120	120	140
<b>Turret</b>					
Number of tools		T10(T12)	T12	T12	T10
Turning tool shank	mm	25	25	25	25
Boring bar shank diameter	mm	T10(50)   T12(40)	40	40	50
Milling tool shank diameter	mm	---	20	20	---
<b>Tailstock</b>					
Tailstock travel	rpm	730[1130]	730[1130]	730[1130]	1050
Tailstock spindle diameter		110	110	110	110
Taper hole of tailstock spindle		MT.5	MT.5	MT.5	MT.5
Tailstock spindle travel	mm	150	150	150	150
<b>Feedrate</b>					
X axis rapid traverse rate	m/min	16	16	16	16
Z axis rapid traverse rate	m/min	20	20	20	20
Y axis rapid traverse rate	m/min	---	---	8	---
<b>Motor</b>					
Spindle drive motor	kW	15/18.5	15/18.5	15/18.5	18.5/22
Milling motor	kW	---	3.7/5.5	3.7/5.5	---
Turret index motor	kW	1.2	1.2	1.2	1.2
X axis drive motor	kW	1.8	1.8	2.5	1.8
Z axis drive motor	kW	2.5	2.5	2.5	2.5
Y axis drive motor	kW	---	---	2.5	---
<b>Size</b>					
Width	mm	2925[3682]	2925[3682]	2925[3682]	3682
Height	mm	1745	1815	2095	1870
Depth	mm	1953[1962]	1962	2027	1962
Weight	kg	4500[7450]	4550[7500]	6200[9300]	7500

※ Specifications are subject to change without notice.



## Standard and optional accessories

☆ : Standard accessories --- : NO ◎ : Optional accessories

Item	LA-250[L]	LA-250M[L]	LA-250Y[L]	LA-300
<b>Accessories</b>				
Variable speed spindle	☆	☆	☆	☆
Hi-low Gearbox Spindle	◎	◎	◎	◎
Built in spindle motor	---	---	---	---
Hydraulic servo turret	☆	☆	☆	☆
Hydraulic tailstock	☆	☆	☆	☆
Manual tailstock base	---	---	---	---
Manual PIN tailstock base	☆	☆	☆	☆
Automatic PIN tailstock base	◎	◎	◎	◎
Boring bar tool holder (4PCS)	☆	☆	☆	☆
U-drill tool holder (1PCS)	☆	☆	☆	☆
Angle type tool holder (1PCS)	☆	☆	☆	☆
OD tool holder(1PCS)	---	☆	☆	---
Boring bar bush ø6	☆	☆	☆	☆
Boring bar bush ø8	☆	☆	☆	☆
Boring bar bush ø10	☆	☆	☆	☆
Boring bar bush ø12	☆	☆	☆	☆
Boring bar bush ø16	☆	☆	☆	☆
Boring bar bush ø20	☆	☆	☆	☆
Boring bar bush ø25	☆	☆	☆	☆
Boring bar bush ø32	☆	☆	☆	☆
Boring bar bush ø40	☆(T10)(T12)	---	---	☆
U-drill bush ø16	☆	☆	☆	☆
U-drill bush ø20	☆	☆	☆	☆
U-drill bush ø25	☆	☆	☆	☆
U-drill bush ø32	☆	☆	☆	☆
U-drill bush ø40	☆	---	---	☆
Drill bush MT.1	◎	◎	◎	◎
Drill bush MT.2	◎	◎	◎	◎
Drill bush MT.3	◎	◎	◎	◎
Drill bush MT.4	◎	◎	◎	◎
X axis live tool holder (1PCS)	---	☆	☆	---
Z axis live tool holder (1PCS)	---	☆	☆	---
Hanger (2PCS)	◎	◎	◎	◎
Leveling pad	☆	☆	☆	☆
Wedge	☆	☆	☆	☆
Working lamp	☆	☆	☆	☆
Tool box	☆	☆	☆	☆
Operation manual	☆	☆	☆	☆
Hydraulic chuck	☆	☆	☆	☆
Foot switch	☆	☆	☆	☆

※ Specifications are subject to change without notice.

Item	LA-250	LA-250M[L]	LA-250Y[L]	LA-300
<b>Optional accessories</b>				
Chip conveyor & chip cart	◎	◎	◎	◎
Tool setter	◎	◎	◎	◎
Parts catcher	◎	◎	◎	◎
Parts conveyor	◎	◎	◎	◎
Barfeeder & Interface	◎	◎	◎	◎
Air blow	◎	◎	◎	◎
Automatic Power-off	◎	◎	◎	◎
Parts counter	◎	◎	◎	◎
Collet chuck	◎	◎	◎	◎
Manual steady rest	◎	◎	◎	◎
Hydraulic steady rest	◎	◎	◎	◎



Collet chuck



Rotating tail stock  
High thrust and clamping forces provide maximum stability especially when working with long workpieces.



Manual steady rest



Oil mist collector

# LA

## 250/300 SERIES



Parts catcher

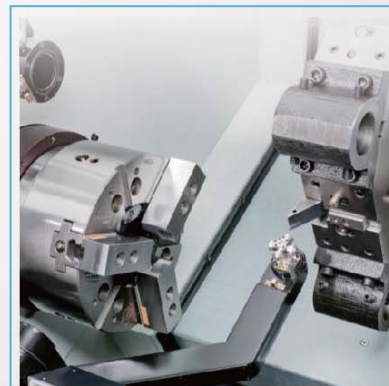

Tool setter