

# SUPER DUTY CNC TURNING CENTER

**LS-800(M)** / (1000) (1500) (2000) (3000)

**LS-800(Y)** / (2000) (3000)

**LS-1000(M)** / (1000) (1500) (2000) (3000)

**LS-1100** / (2000) (3000) (4000)

## TAKISAWA ADVANCED ENGINEERING AND MACHINE DESIGN

- Super Duty one-piece cast iron construction featuring high dampening coefficient with minimal thermo deformation.
- 45° slant bed design provides optimal cutting condition.
- The slideways, hardened by high frequency induction, offer ideal hardness characteristics.
- Hand scraped Turcite B ensures static as well as dynamic accuracy between all contact surfaces.
- Our highly rigid spindle features deformation resistance, powerful turning capability and rugged durability.
- Taiwan Takisawa produced Super Duty turret features rapid positioning and the largest available 18" diameter curvic coupling. This massive turret is 31.5" in diameter and 7.8" thick.
- The two-step gearbox offers extraordinarily high torque during low speed machining for outstanding Super Duty cutting performance.



# SPINDLE SPECIFICATIONS



Taiwan Takisawa in-house produced spindle adopts high quality bearing imported from Europe or Japan. The spindle and fine-bored cast iron housing is assembled in the air-conditioned room, the high accuracy performance features optimum cutting capability, easy maintenance, short delivery time and low cost for service spare parts.



## GEAR BOX

Taiwan Takisawa full series CNC lathe employs gearbox made from 0-grade fine ground high precision gears. The gearbox unit is assembled and test-ran in the humidity and temperature controlled room to ensure low temperature rising, low noise and low vibration. The Gearbox is capable of providing high cutting torque during low speed range, which is suitable for heavy cutting, in the mean time still keep good surface finish of work piece.

### LS-800

SPINDEL DRIVE MOTOR

**A / MY**

22/26 kW (30/35 HP)

Through hole diameter

102

MAX. SPINDLE SPEED (min<sup>-1</sup>)

2000 (15")

**B / MY**

22/26 kW (30/35 HP)  
30/37 kW (40/50 HP)

117

2000 (15") / 1500 (18")  
2000 (15") / 1500 (18")

**C / M**

30/37 kW (40/50 HP)  
37/45 kW (50/60 HP)

200

1200 (20")  
1200 (20")

### LS-1000

SPINDEL DRIVE MOTOR

**A / MY**

30/37 kW (40/50 HP)

200

2000 (15")

**B / M**

30/37 kW (40/50 HP)  
37/45 kW (50/60 HP)

200

1200 (20") / 1000 (24")  
1200 (20") / 1000 (24")

### LS-1100

SPINDEL DRIVE MOTOR

**A / MY**

37/45 kW (50/60 HP)  
45/55 kW (60/75 HP)

275

900

900

STANDARD  
OPTION

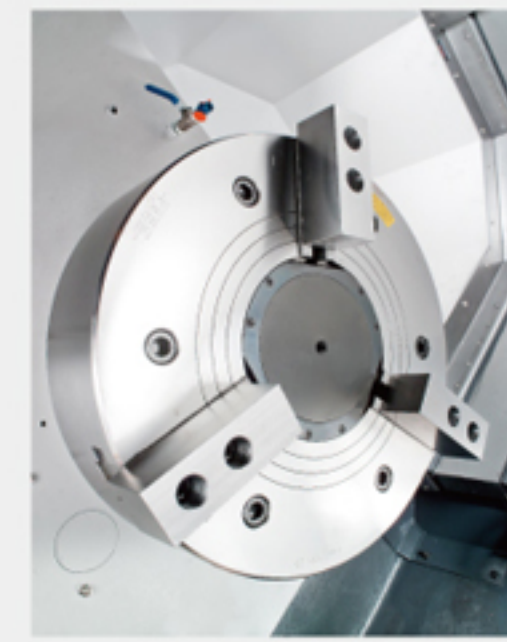

# SPINDLE OUTPUT DIAGRAM

LS-1000(M) SPINDLE OUTPUT DIAGRAM

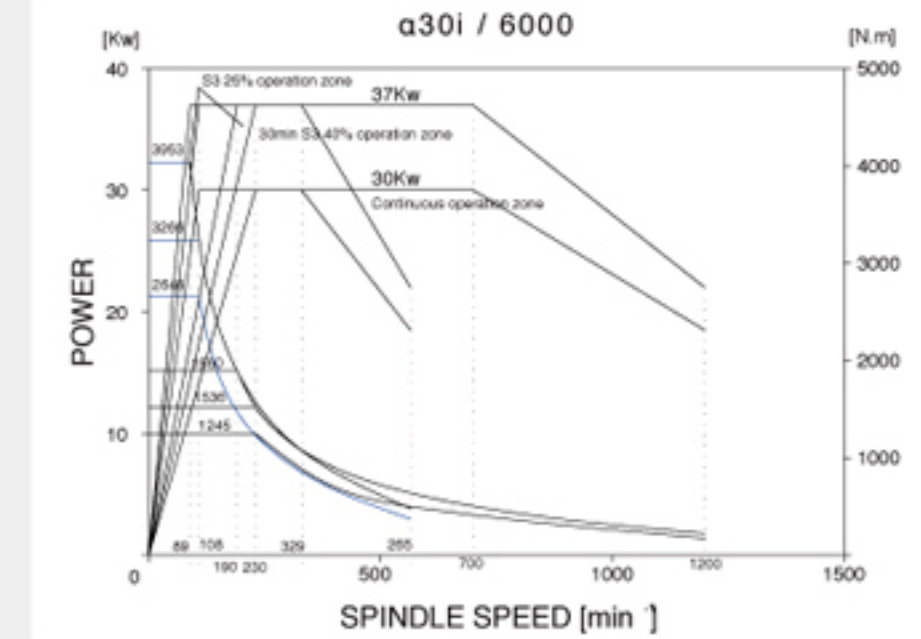

LS-800(M) B TYPE SPINDLE OUTPUT DIAGRAM

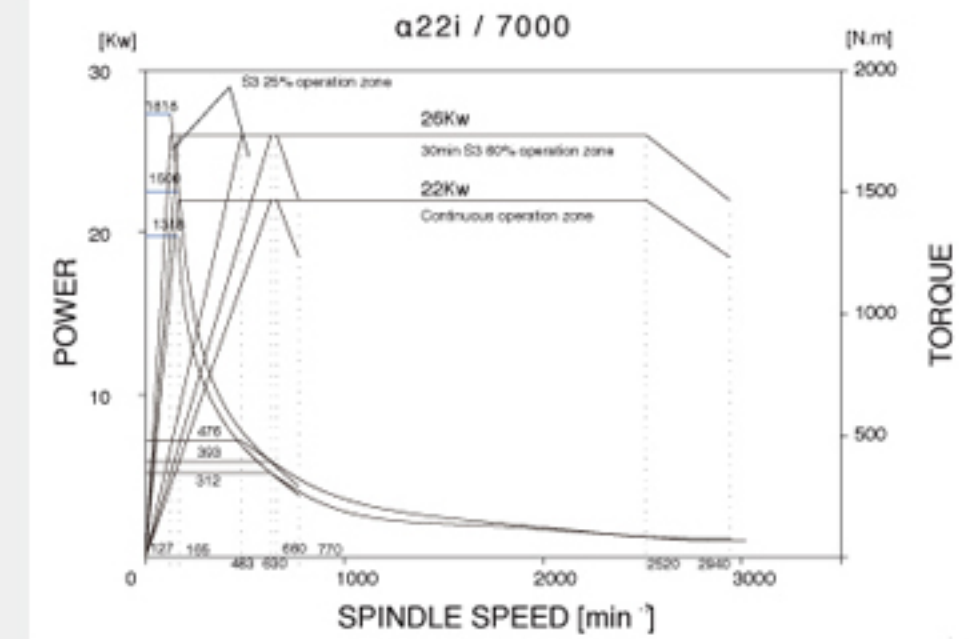

LS-1100 SPINDLE OUTPUT DIAGRAM

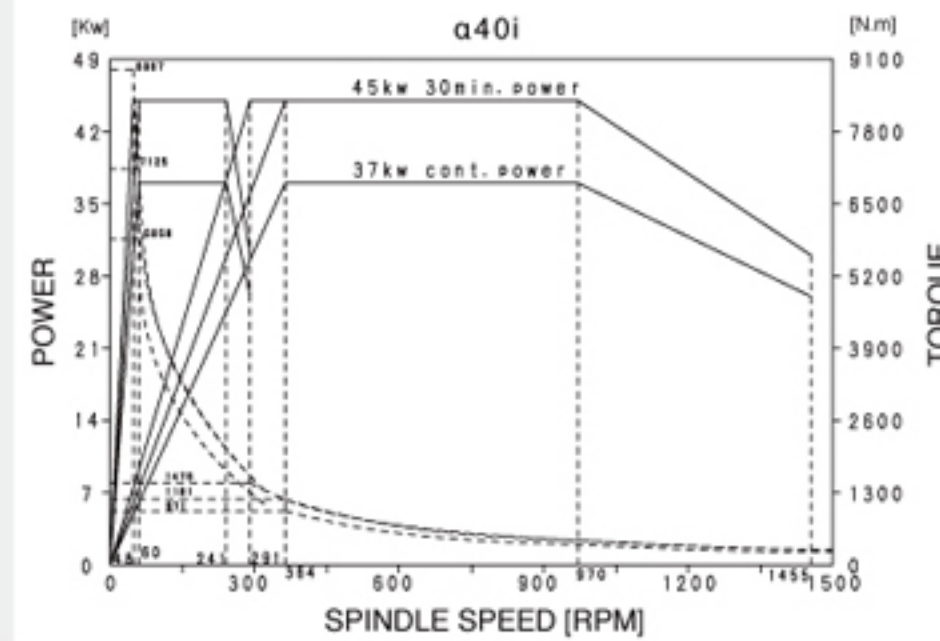

LS-1000(M) SPINDLE OUTPUT DIAGRAM

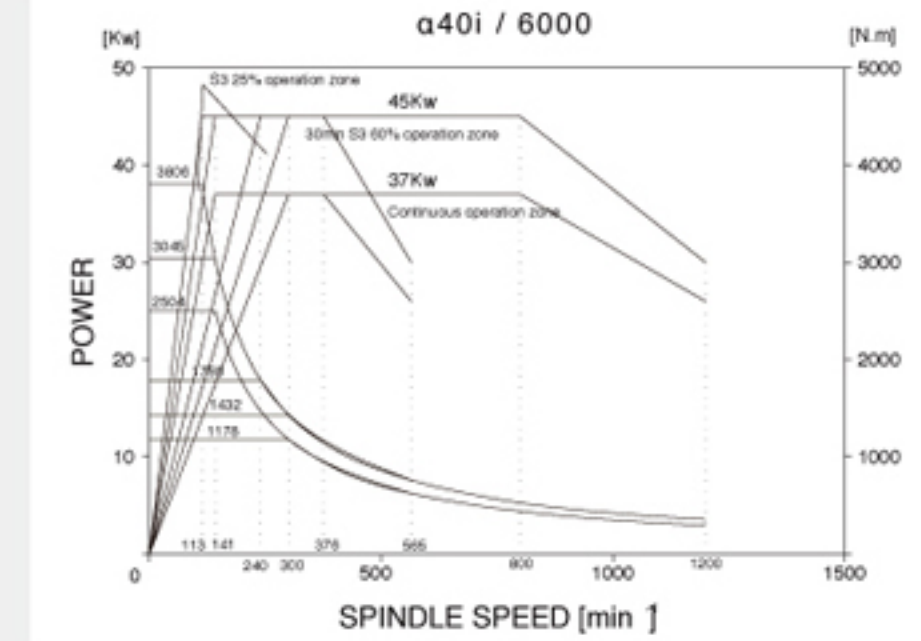

LS-800(M) B TYPE SPINDLE OUTPUT DIAGRAM

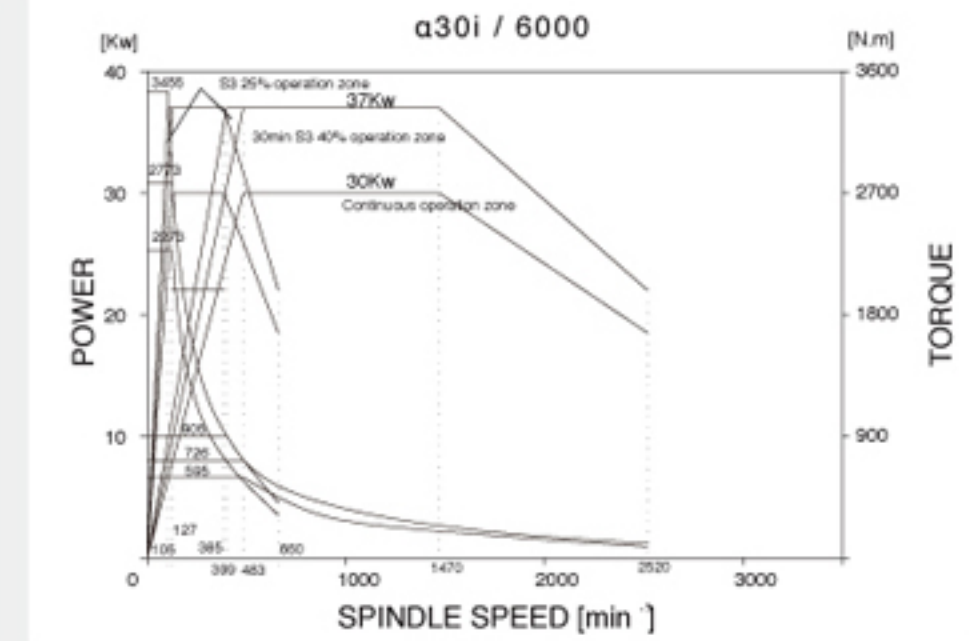

LS-1100 SPINDLE OUTPUT DIAGRAM

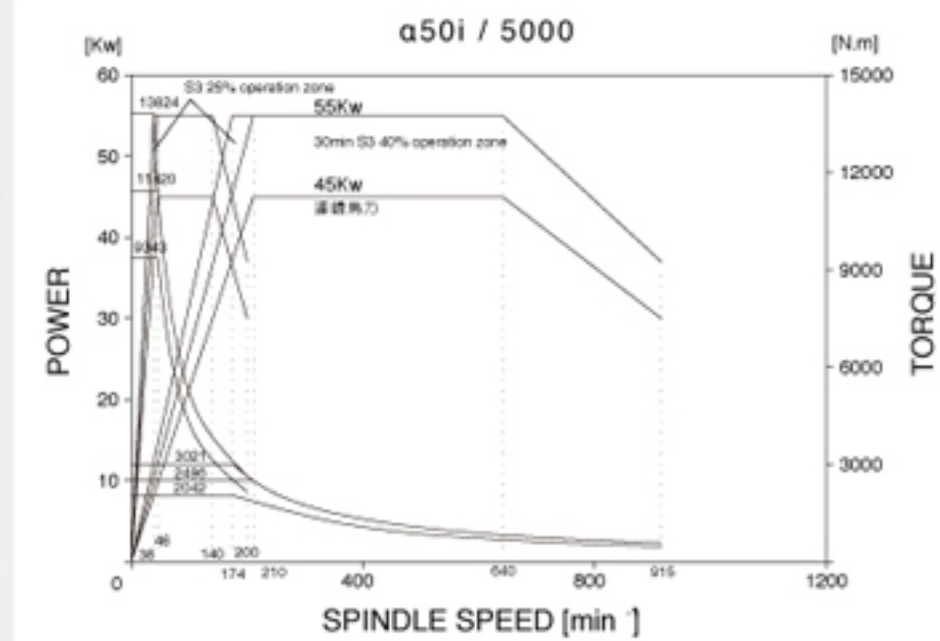

LS-800(M) A TYPE SPINDLE OUTPUT DIAGRAM

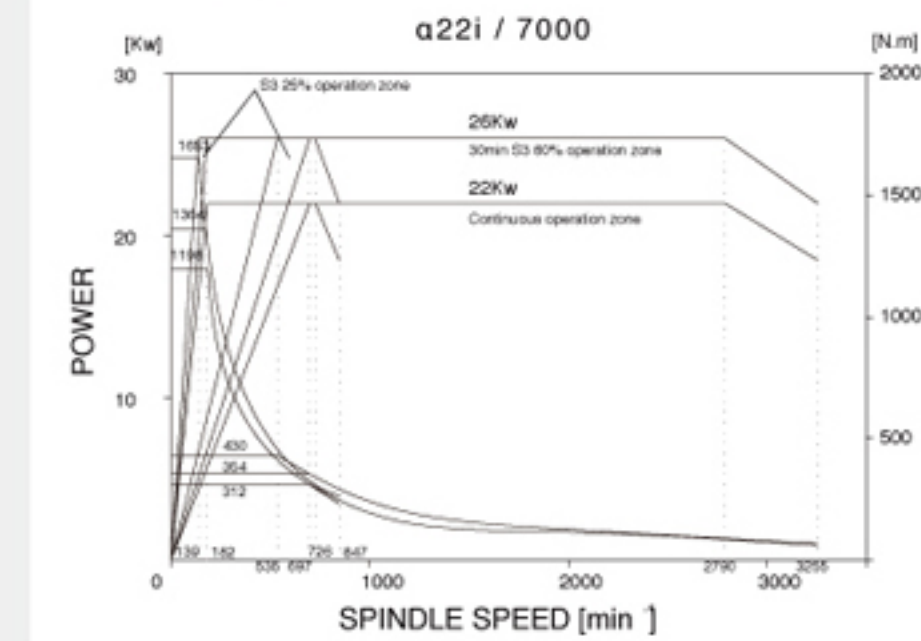

LS-800(M) C TYPE SPINDLE OUTPUT DIAGRAM

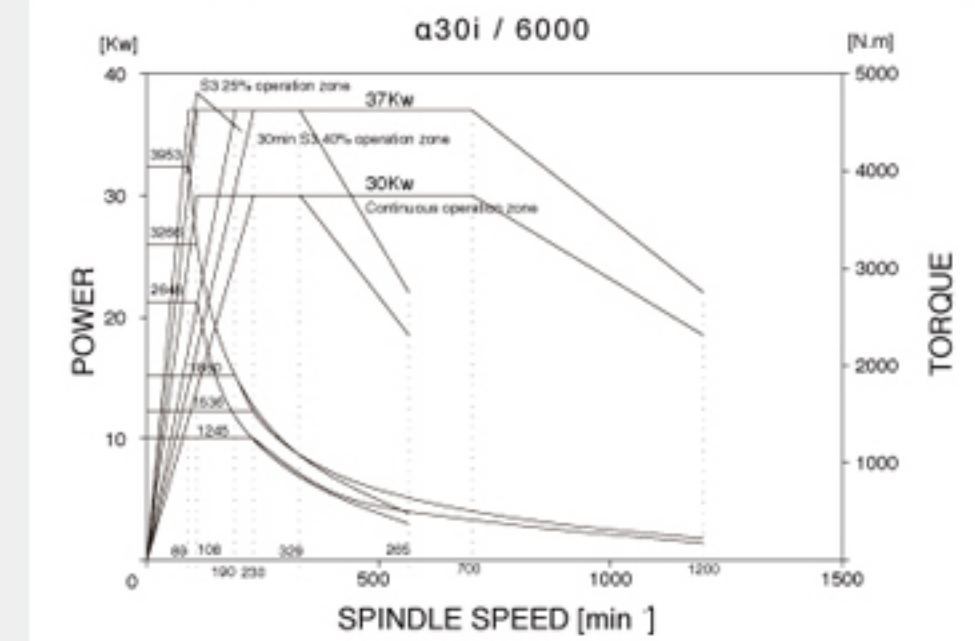

# TURRET SPECIFICATIONS

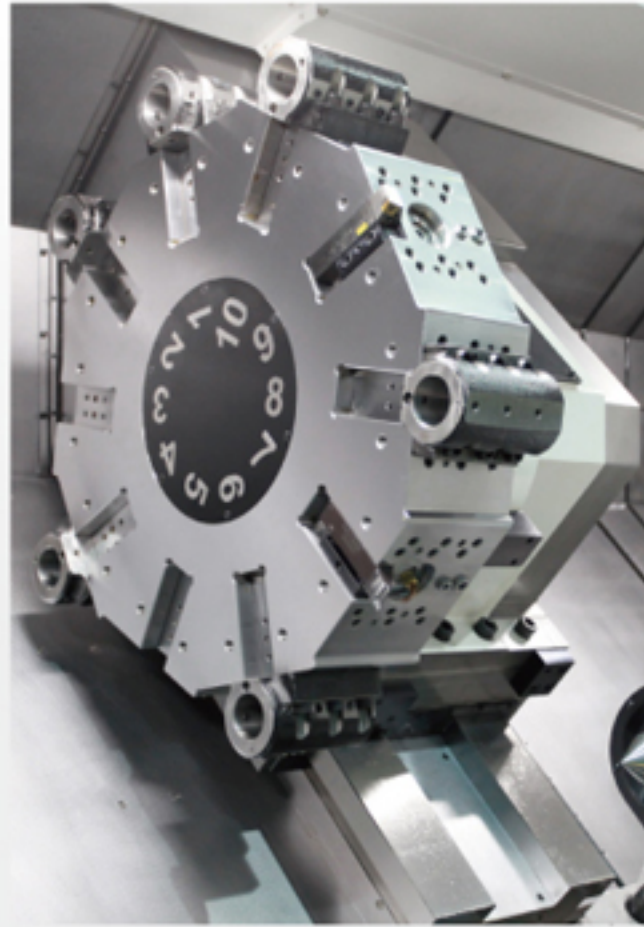

The high performance turrets are all made by Taiwan Takisawa. The two-piece high precision coupling features high clamping force, rapid accurate index, and easy to calibrate position in both CW and CCW direction.

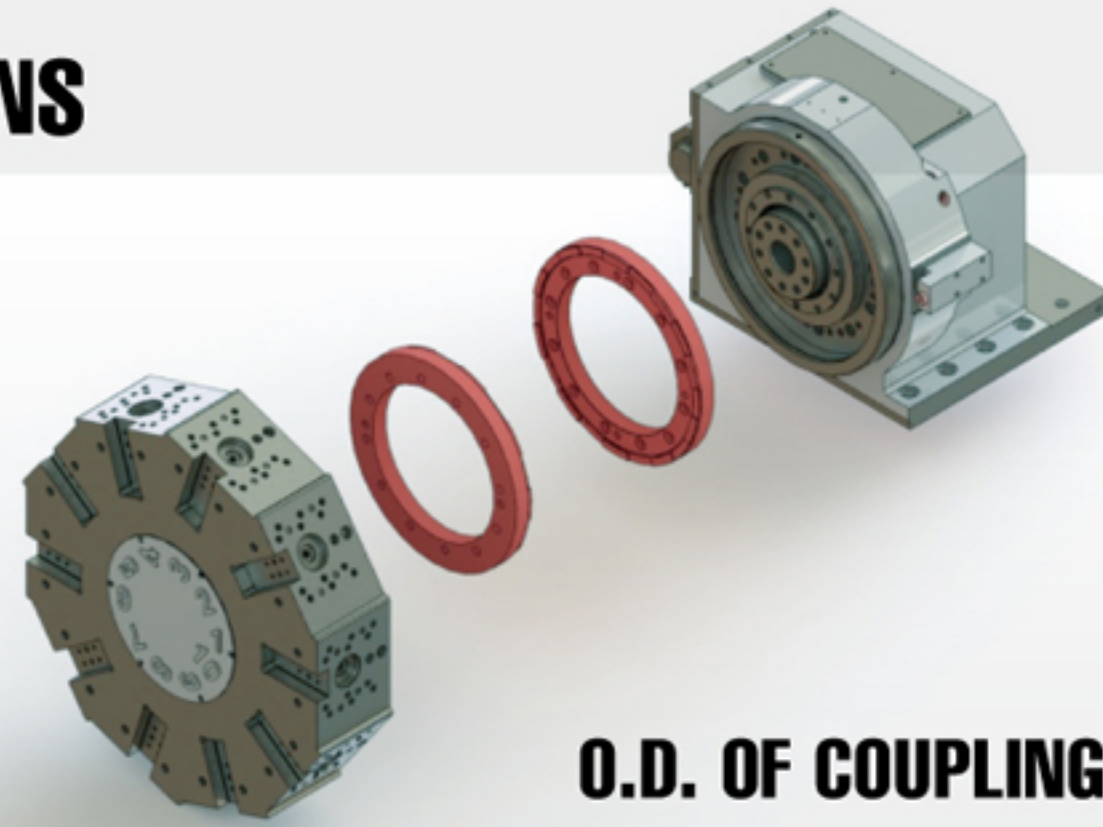

## O.D. OF COUPLING

LS-800: **250** mm

LS-1000: **360** mm

LS-1100: **460** mm



LS-800M/Y (std. 5.5/7.5kw, opt. 7.5/11kw)  
LS-1000M (std. 7.5/11kw)

## POWER CHART OF MILLING TOOL

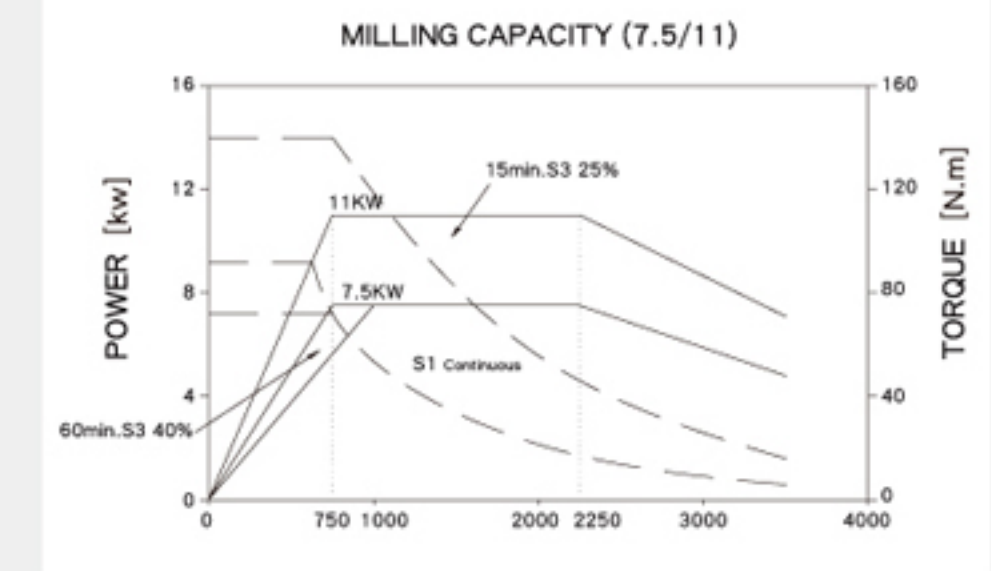
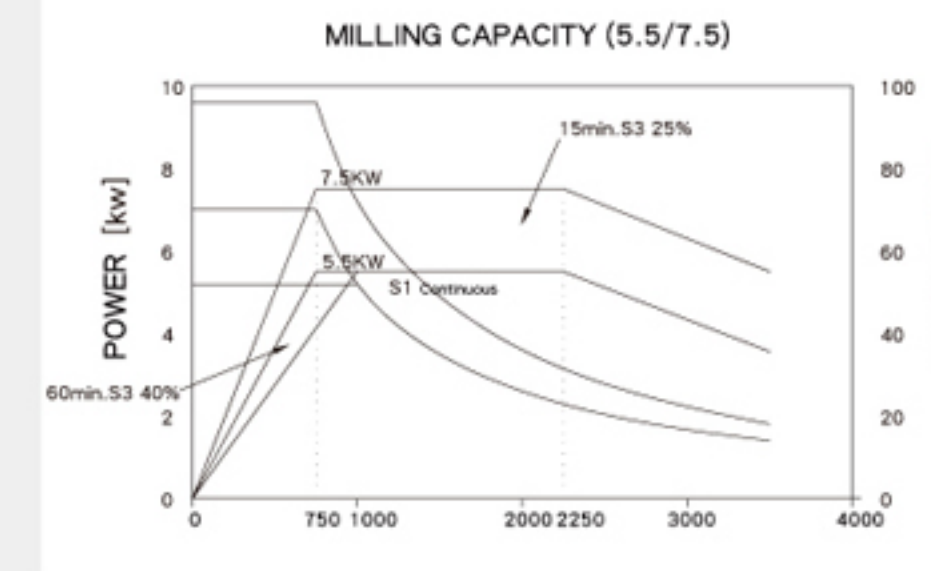

## MACHINING PERFORMANCE

O.D. HEAVY CUTTING	MACHINE MODEL	TOOL	SPINDLE SPEED	CUTTING FEEDRATE	CUTTING DEPTH	FEED PER REV.
	LS-800 α il 22/7000	32 x 32 mm PCLNR 3232P 19	267 rpm	120 m/min	13 mm	0.8 mm/rev
	LS-1100 α il 50/5000	32 x 32 mm PCLNR 3232P 19	267 rpm	120 m/min	14 mm	0.8 mm/rev
DRILL	MACHINE MODEL	TOOL	DRILLING DIA.	SPINDLE SPEED	CUTTING FEEDRATE	FEED PER REV.
	LS-800 α il 22/7000	Drill	58 mm	250 rpm	120 m/min	0.3 mm/rev
	LS-1100 α il 50/5000	Drill	58 mm	250 rpm	120 m/min	0.3 mm/rev

# FEEDING

Unit: m/min

MACHINE MODEL	X AXIS FEEDRATE	Y AXIS FEEDRATE	Z AXIS FEEDRATE
<b>LS-800 (M)</b>	12	---	L10 / L15 / L20 / L30 20 / 16 / 16 / 12
<b>LS-1000 (M)</b>	12	---	16 / 16 / 16 / 12
<b>LS-1100</b>	12	---	L20 / L30 / L40 12 / 10 / 6
<b>LS-800Y</b>	12	6	L20 / L30 16 / 12



**BALL SCREW**  
Employs high precision high reliability ball screw offers faster rapid feedrate.

## LS Series STRUCTURE

All structural component of the machine is made of stress-relieved and deformation-free cast iron. The contact surfaces are hand-scraped to ensure the minimum tolerance accumulation.

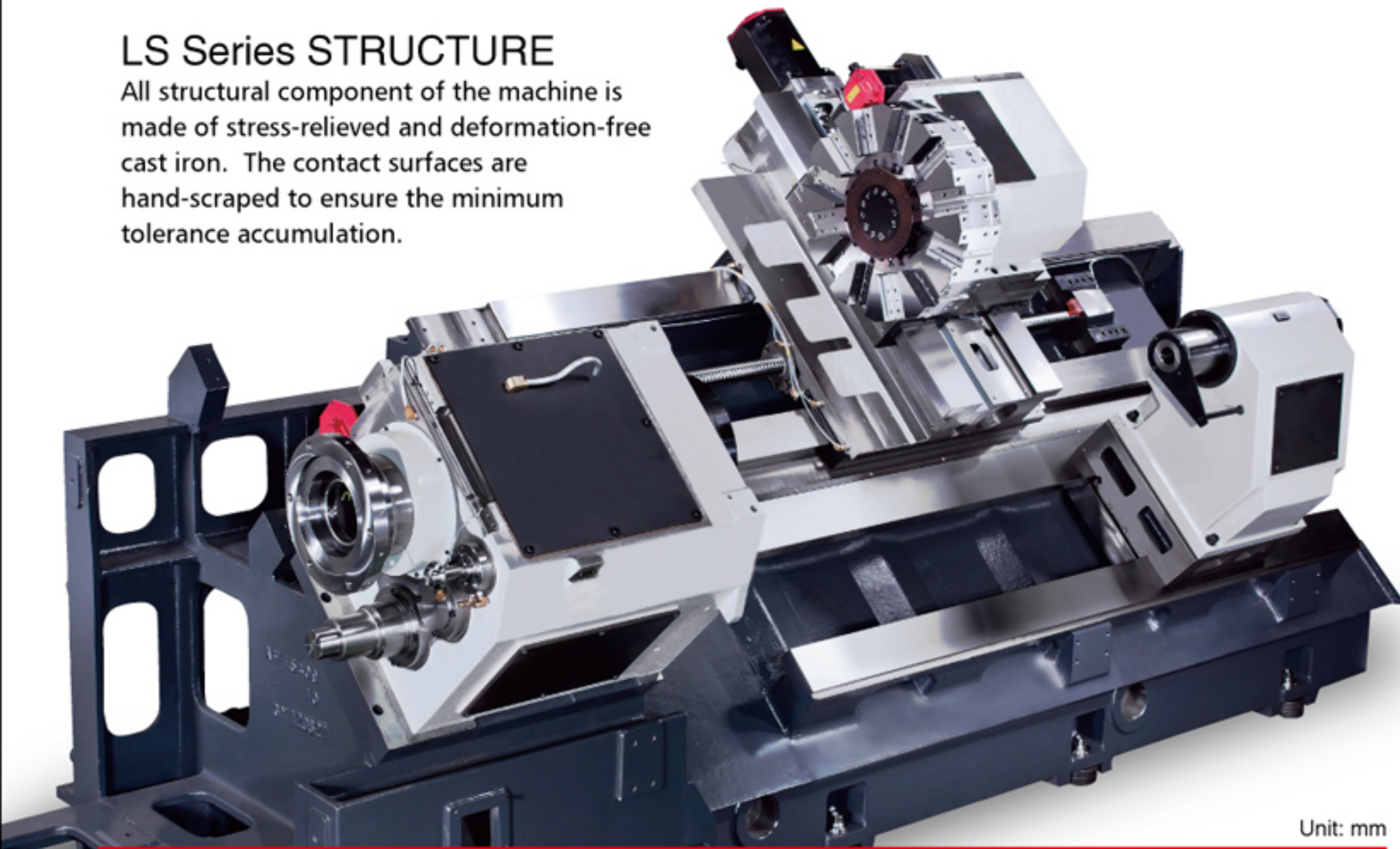

## TAIL STOCK CAPABILITY

Unit: mm

MACHINE MODEL	QUILL DIAMETER	QUILL STROKE	CENTER TYPE
<b>LS-800 (M)(Y)</b>	Fixed Quill: 125	120 / (150)	MT.5 (MT.6)
	Live Quill: 150		
<b>LS-1000 (M)</b>	Live Quill: 180	150	MT.6
<b>LS-1100</b>	Live Quill: 200	150	MT.6



High trust and high clamping provides the maximum stability especially when working with long workpiece.

# STANDARD ACCESSORIES



FANUC CONTROLLER



CHIP CONVEYOR



LUBRICATION PUMP

# OPTIONAL ACCESSORIES

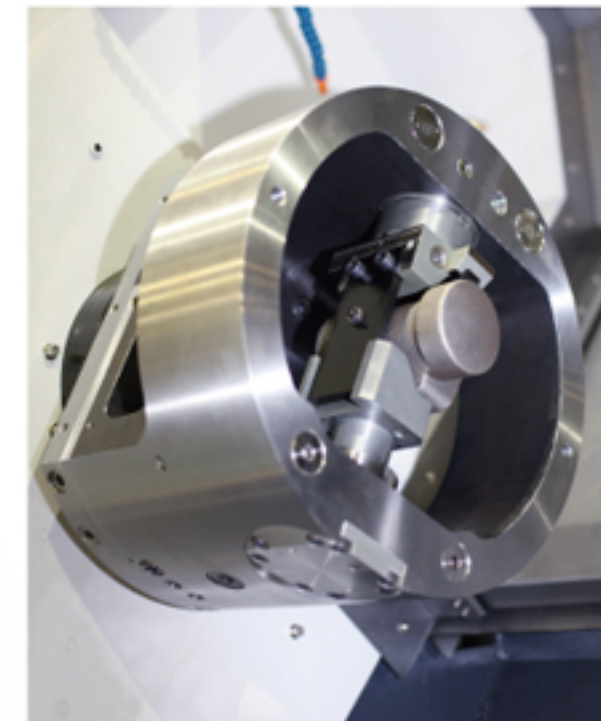

INDEXING CHUCK



OIL COOLER

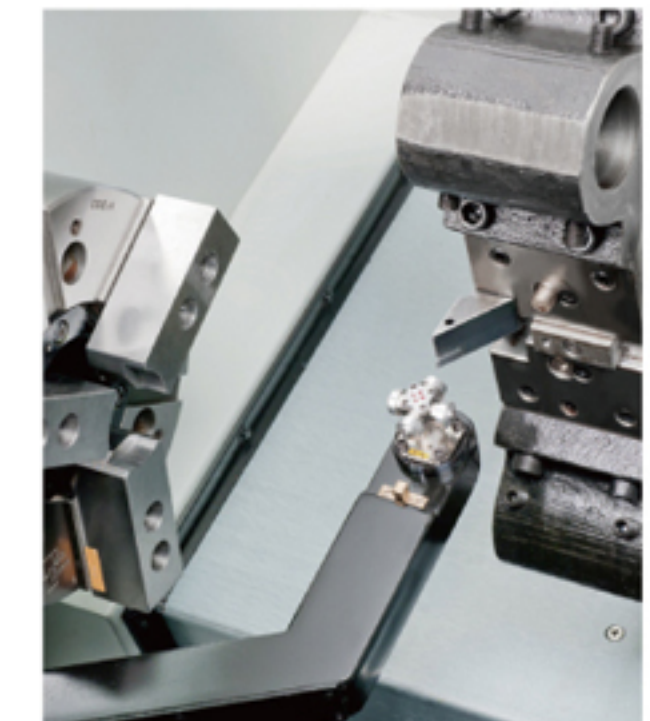

TOOL SENSOR

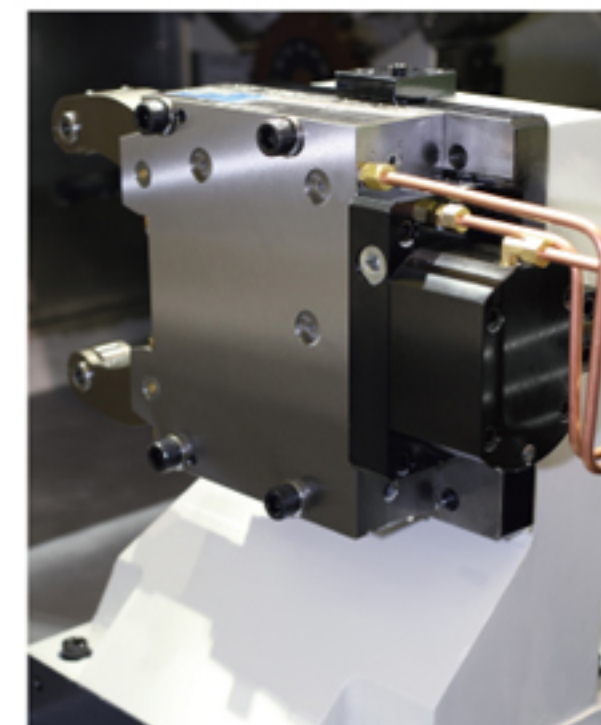

STEADY REST



OIL COOLER FOR GEARBOX

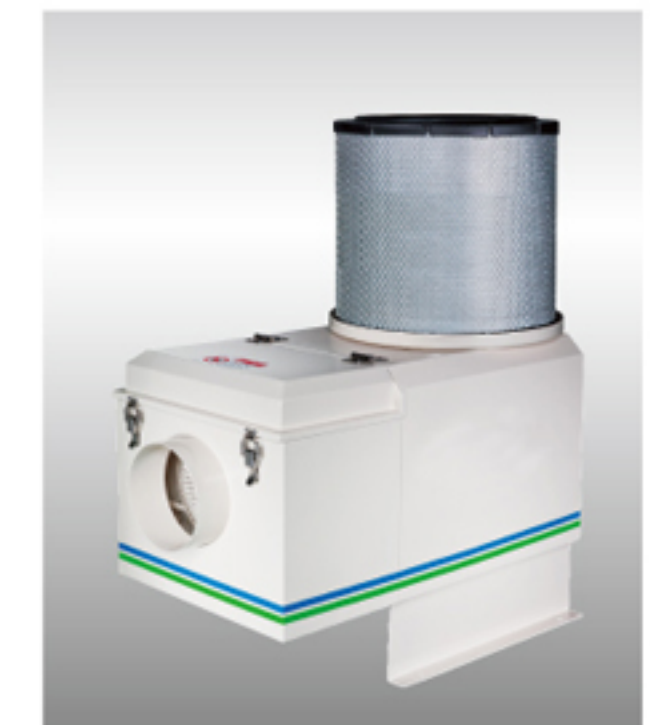

OIL MIST COLLECTOR

# INTERFERENCE DIAGRAM

# WORKING RANGE

**LS-800** Interference Diagram

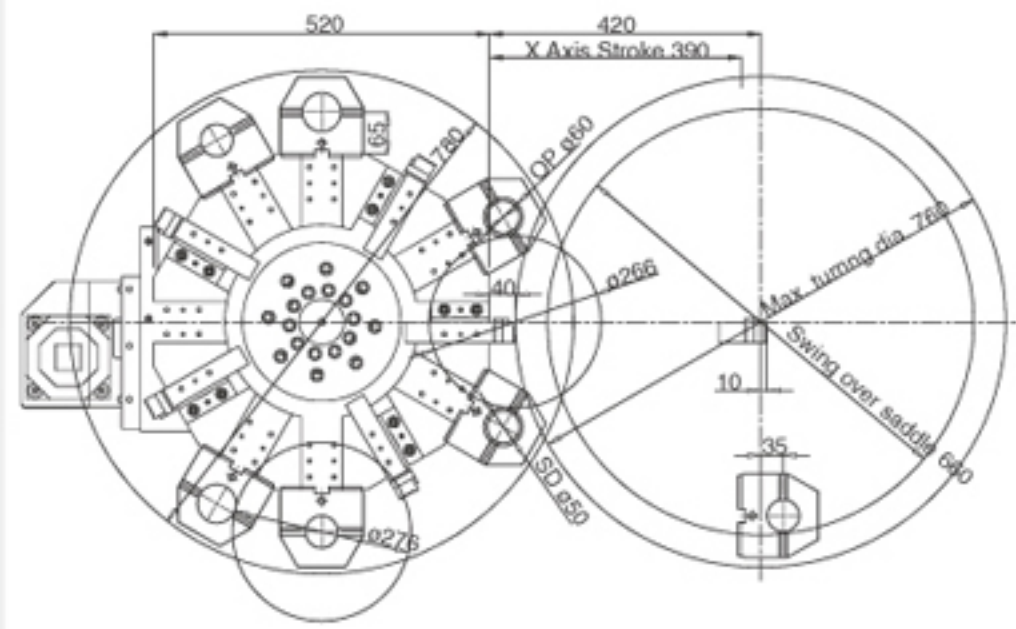

**LS-1000** Interference Diagram

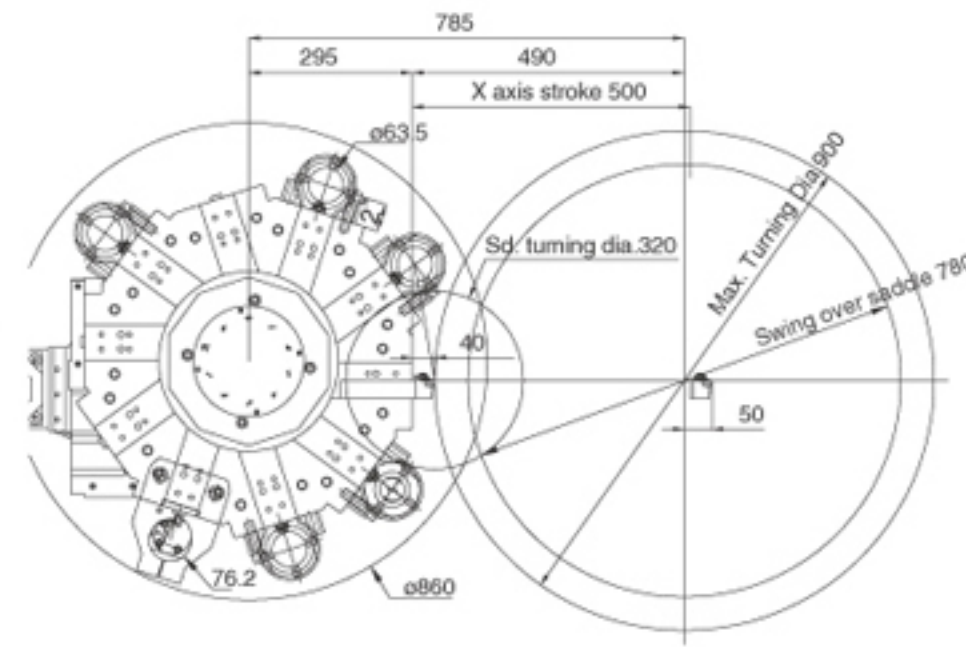

**LS-800** Working Range

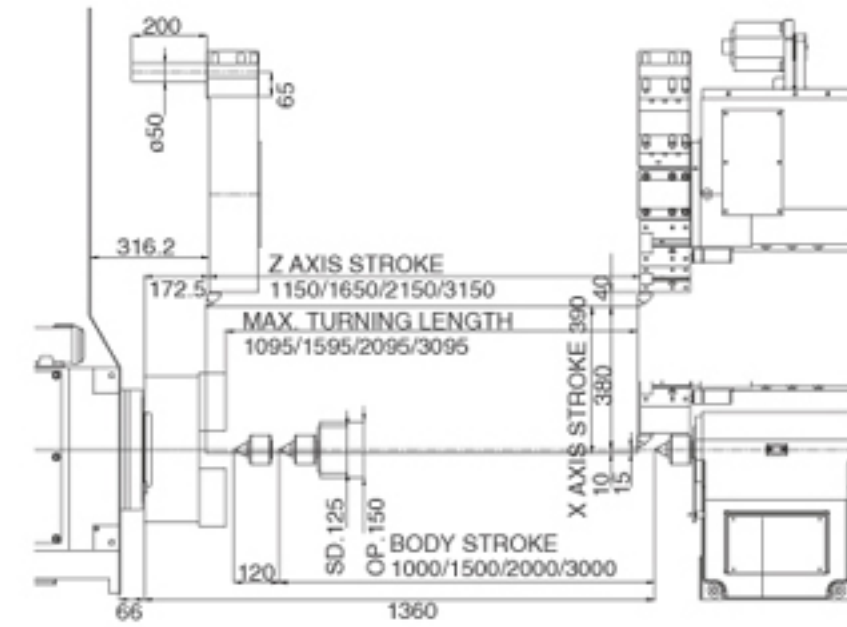

**LS-1000** Working Range

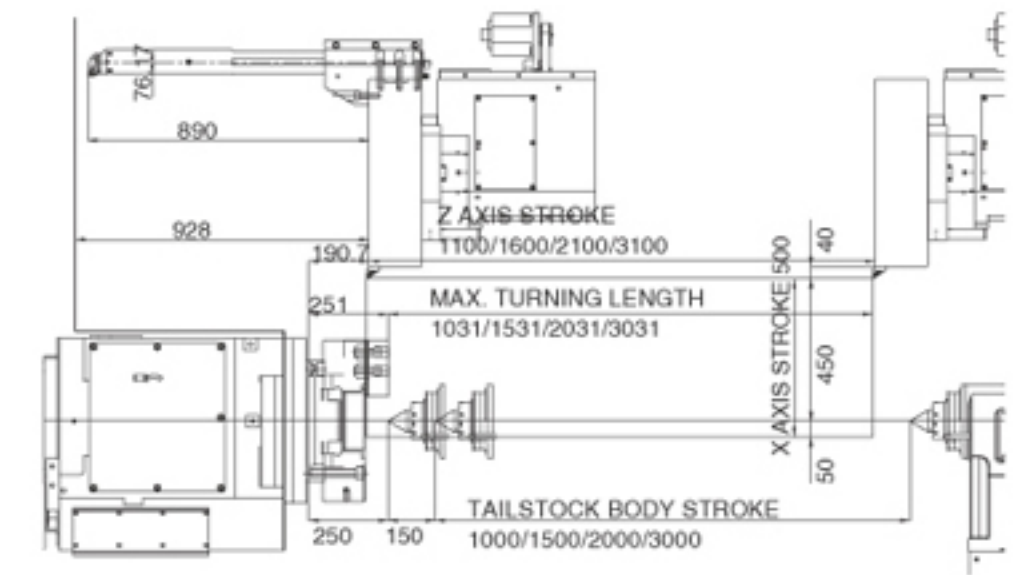

**LS-800M** Interference Diagram

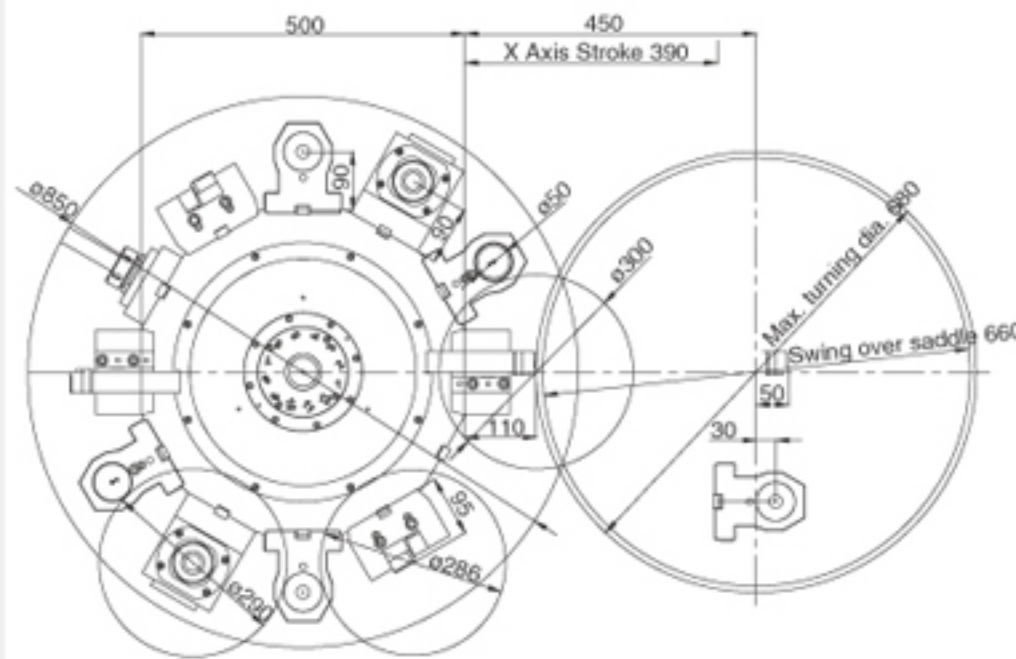

**LS-1000M** Interference Diagram

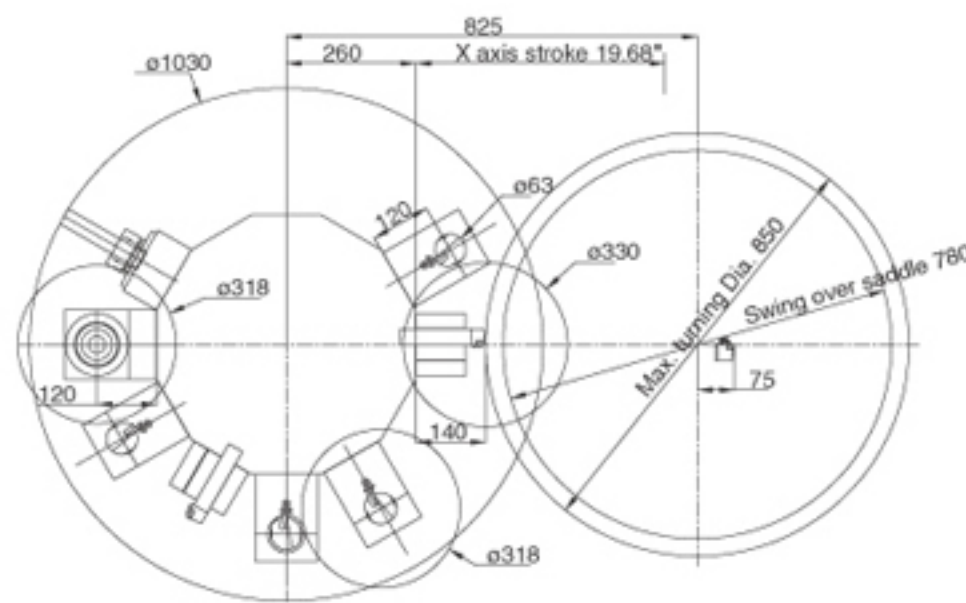

**LS-800M** Working Range

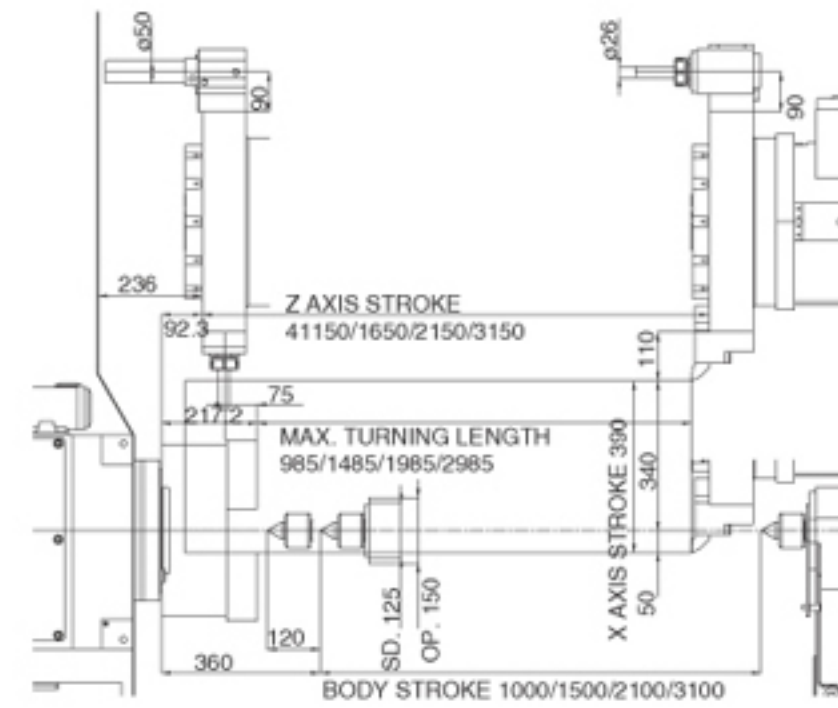

**LS-1000M** Working Range

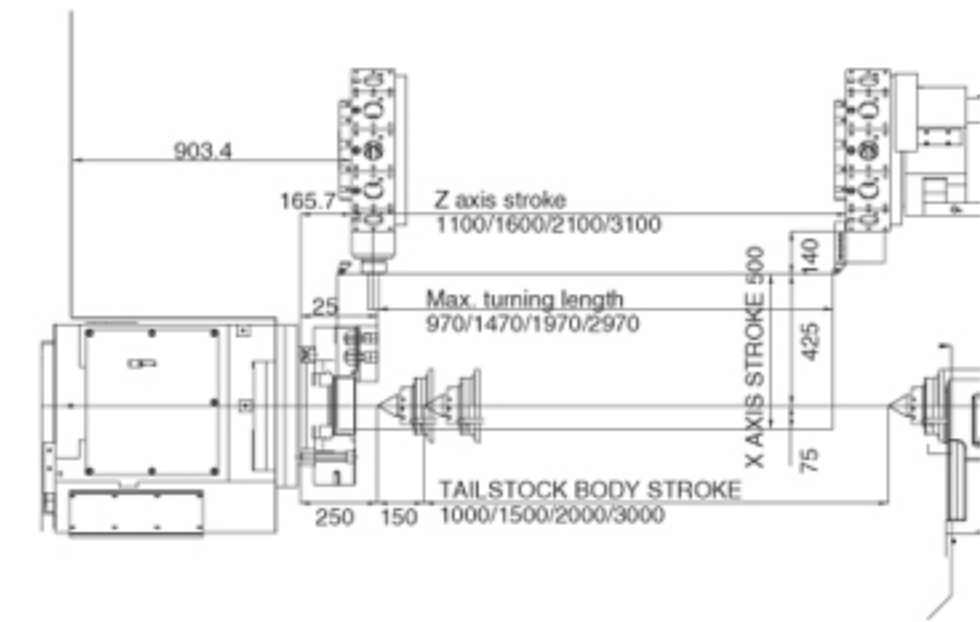

**LS-800Y** Interference Diagram

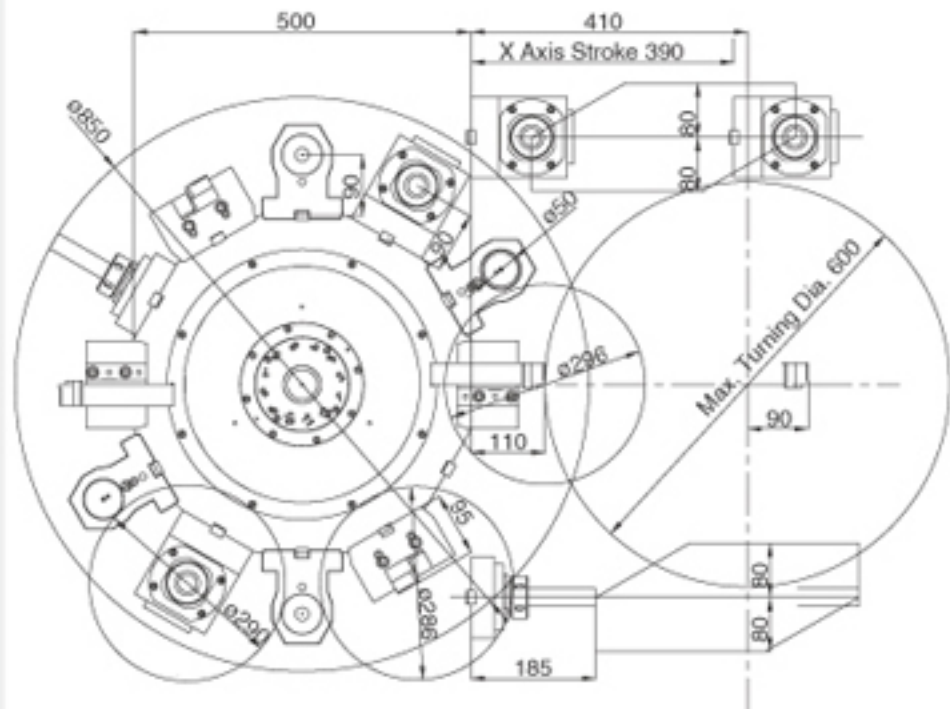

**LS-1100** Interference Diagram

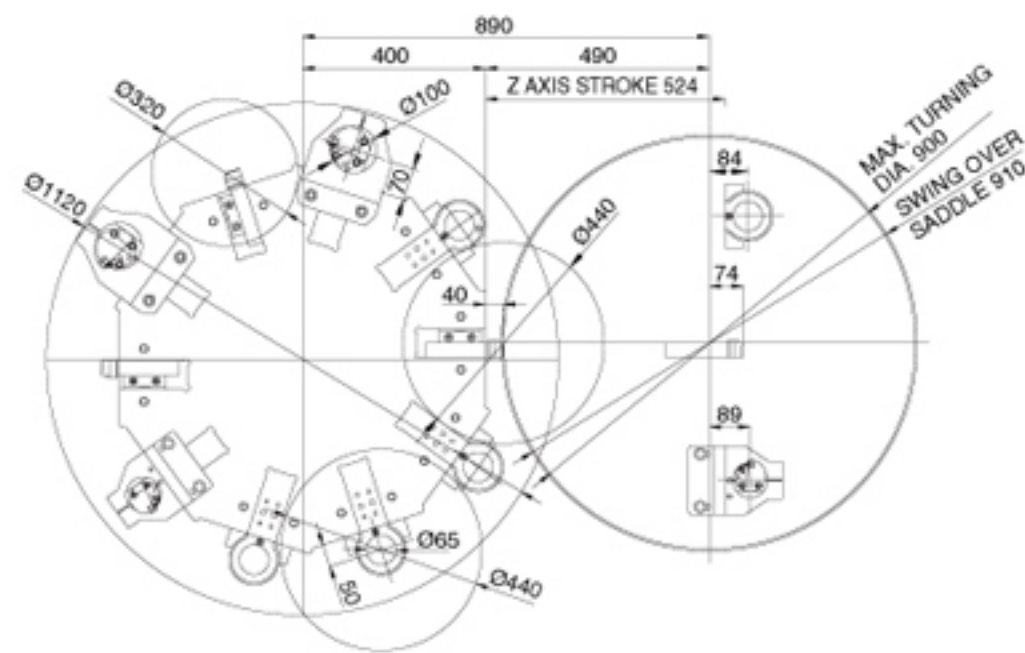

**LS-800Y** Working Range

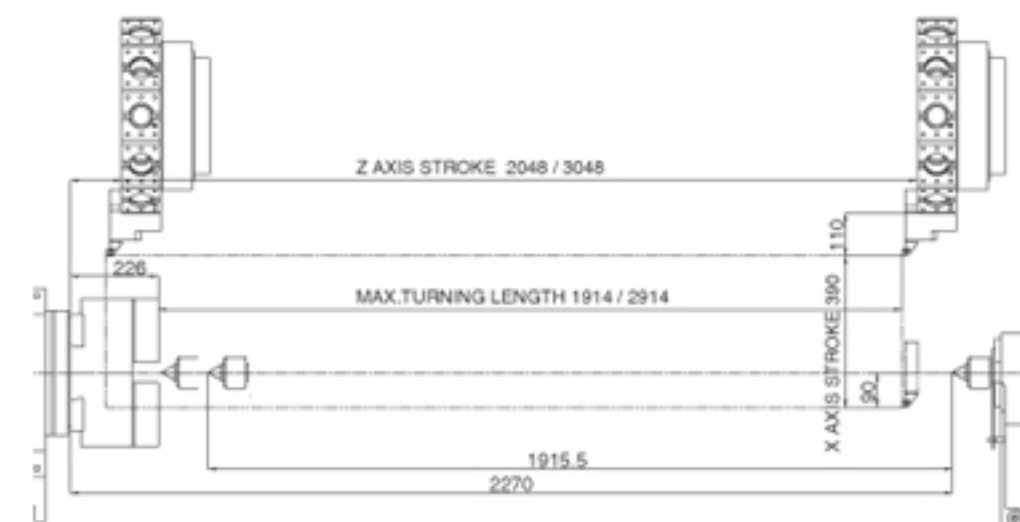

**LS-1100** Working Range

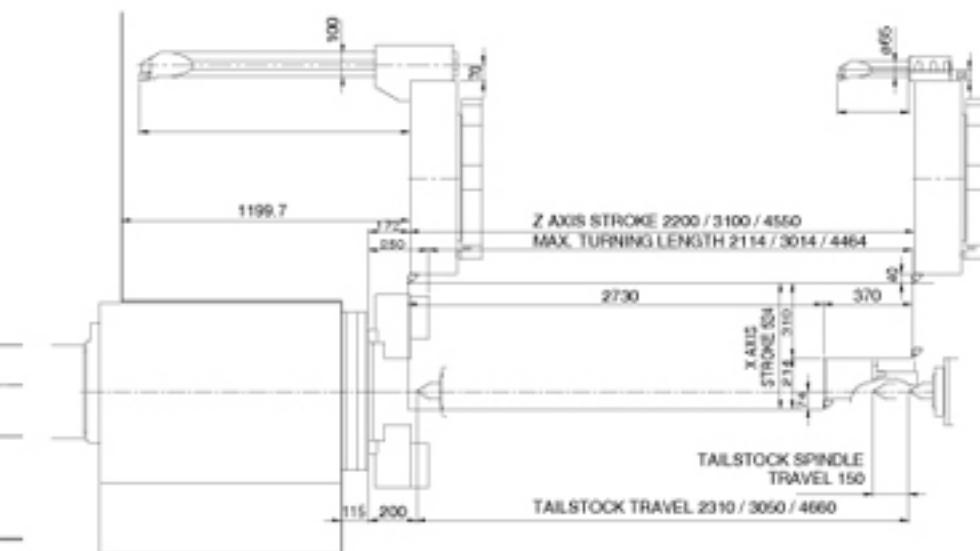

# TOOLING SYSTEM

## LS-800 TOOLING SYSTEM

TOOL HOLDER	FACING HOLDER AH22003-001(mm) AH22027-001(inch)		
BORING BAR	BUSH	ø6(mm) / ø1/4"(inch)	BORING BAR, DRILL HOLDER AH22051-002(mm) AH22076-002(inch)
		ø8(mm) / ø5/16"(inch)	
		ø10(mm) / ø3/8"(inch)	
		ø12(mm) / ø1/2"(inch)	
		ø16(mm) / ø5/8"(inch)	
		ø20(mm) / ø3/4"(inch)	
		ø25(mm) / ø1"(inch)	
DRILL	BUSH	MT.1(mm) / MT.1(inch)	TURRET(12T) AH21001-001(mm) AH21002-001(inch)
		MT.2(mm) / MT.2(inch)	
		MT.3(mm) / MT.3(inch)	
		MT.4(mm) / MT.4(inch)	
U DRILL	BUSH	ø16(mm) / ø1/2"(inch)	U DRILL HOLDER AH22054-002(mm) AH22078-002(inch)
		ø20(mm) / ø20"(inch)	
		ø25(mm) / ø25"(inch)	
		ø32(mm) / ø32"(inch)	
		ø40(mm) / ø40"(inch)	

## LS-1000 TOOLING SYSTEM

TOOL HOLDER	TURNING HOLDER NJ22032-001(mm)		LS-1000 TURRET 12T NQ21102-001
BORING BAR	FACING HOLDER NJ22017-001(mm) NJ22003-001(inch)		BORING BAR, DRILL HOLDER NJ22015-001(mm) NJ22001-001(inch)
	BUSH	ø20(mm) / ø3/4"(inch)	
		ø25(mm) / ø1"(inch)	
		□=25L(mm) / □=25L(inch)	
		□=25L(mm) / □=25L(inch)	
		ø32(mm)	
		ø40(mm)	
DRILL	BUSH	MT.4(mm) / MT.4(inch)	BORING BAR, DRILL HOLDER(3")
		MT.5(mm) / MT.5(inch)	
U DRILL	BUSH	ø32(mm) / ø1-1/4"(inch)	U DRILL HOLDER NJ22016-001(mm) NJ22002-001(inch)
		ø40(mm) / ø1-1/2"(inch)	
		ø45(mm) / ø1-3/4"(inch)	
		ø50(mm) / ø2"(inch)	

## LS-800(M / Y) TOOLING SYSTEM

TOOL HOLDER	TURNING HOLDER NQ22101-001(mm) NQ22105-001(mm)		
BORING BAR	FACING HOLDER NQ22102-001(mm) NQ22106-001(inch)		BORING BAR, DRILL HOLDER NQ22103-001(mm) NQ21102-001(inch) NQ22107-001(inch)
	BUSH	ø6(mm) / ø1/4"(inch)	
		ø8(mm) / ø5/16"(inch)	
		ø10(mm) / ø3/8"(inch)	
		ø12(mm) / ø1/2"(inch)	
		ø16(mm) / ø5/8"(inch)	
		ø20(mm) / ø3/4"(inch)	
DRILL	BUSH	MT.1(mm) / MT.1(inch)	TURRET(12T) NQ21101-001(mm) NQ21102-001(inch)
		MT.2(mm) / MT.2(inch)	
		MT.3(mm) / MT.3(inch)	
		MT.4(mm) / MT.4(inch)	
U DRILL	BUSH	ø16	U DRILL HOLDER NJ22016-001(mm) NQ22018-001(inch)
		ø20	
		ø32	
		ø40	

## LS-1000M TOOLING SYSTEM

TOOL HOLDER	TURNING HOLDER NJ22126-001(mm) NJ22127-001(mm)		
BORING BAR	FACING HOLDER FA22124-001(mm) NJ22125-001(inch)		BORING BAR, DRILL HOLDER NJ22122-001(mm) NJ22123-001(inch)
	BUSH	ø8(mm) / ø5/16"(inch)	
		ø10(mm) / ø3/8"(inch)	
		ø12(mm) / ø1/2"(inch)	
		ø16(mm) / ø5/8"(inch)	
		ø20(mm) / ø3/4"(inch)	
		ø25(mm) / ø1"(inch)	
DRILL	BUSH	MT.1(mm) / MT.1(inch)	TURRET(12T) NQ21102-001
		MT.2(mm) / MT.2(inch)	
		MT.3(mm) / MT.3(inch)	
		MT.4(mm) / MT.4(inch)	
		MT.5(mm) / MT.5(inch)	
U DRILL	BUSH	ø20(mm) / ø20(inch)	
		ø25(mm) / ø25(inch)	
		ø32(mm) / ø32(inch)	
		ø40(mm) / ø40(inch)	

# MACHINE DIMENSIONS

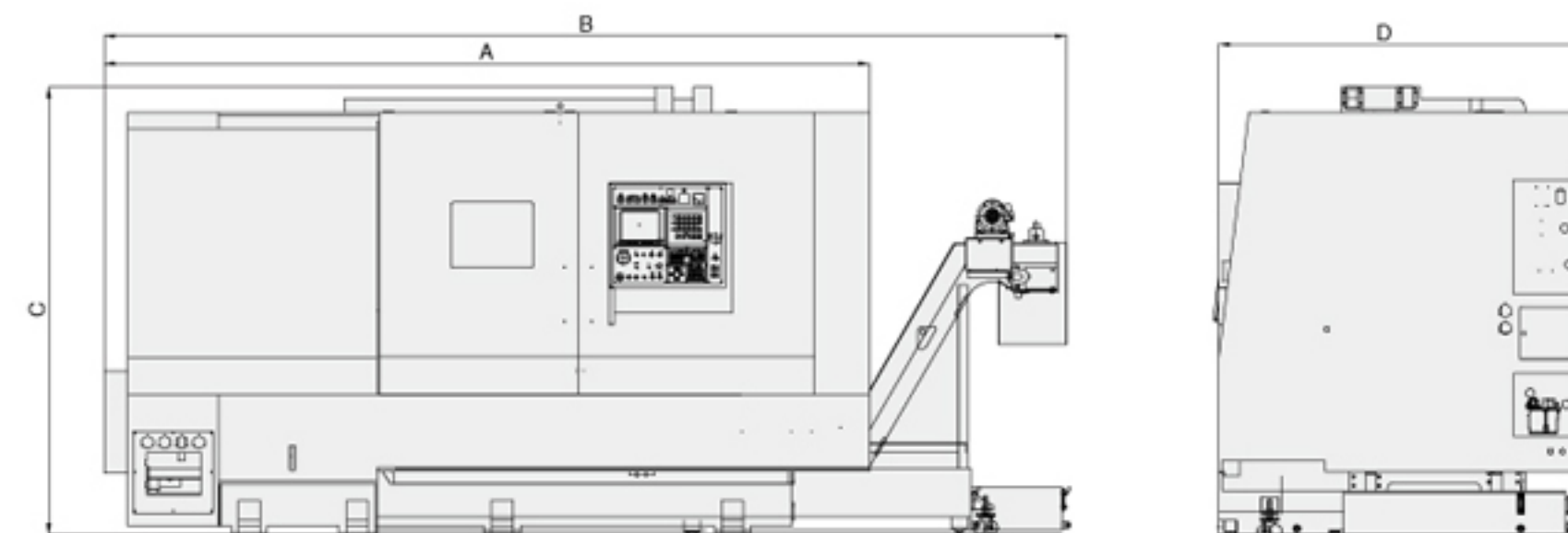

Unit: mm

	LS-800(M)L10	LS-800(M)L15	LS-800(M)L20	LS-800(M)L30	LS-800YL20	LS-800YL30
A	4538	4968	5658	6700	5632	6882
B	5822	6237	6927	7969	6781	8031
C	2402	2402	2402	2423	2762	2762
D	2146	2146	2146	2146	2394C	2893

\* Specifications are subject to change without notice.

# MACHINE DIMENSIONS

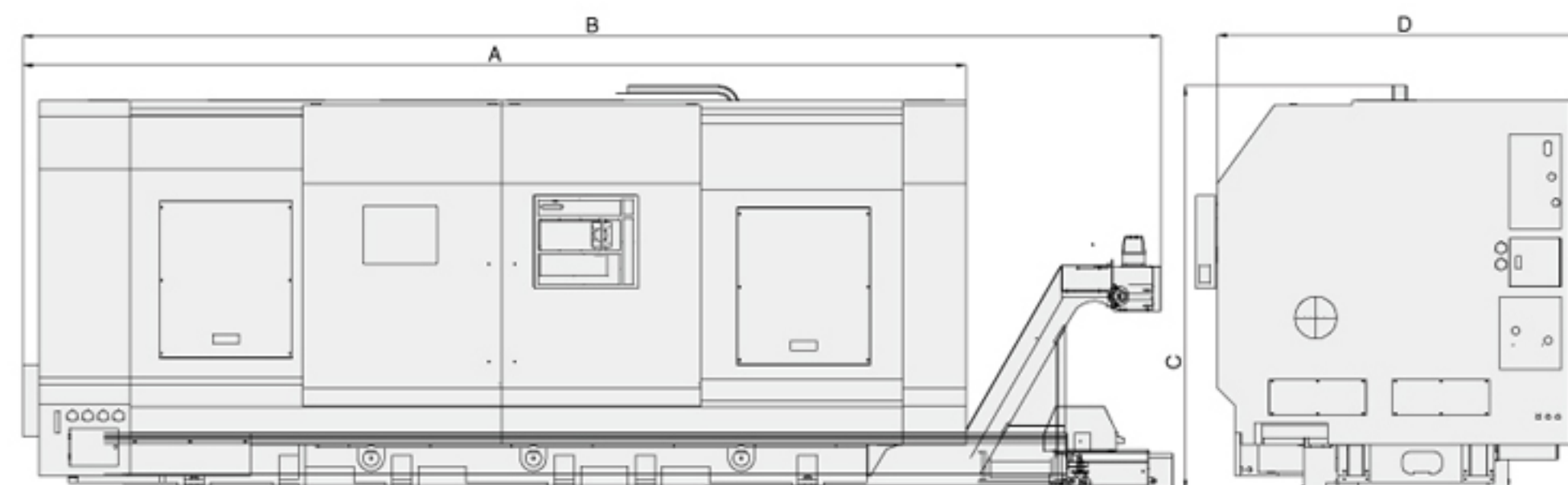

Unit: mm

	LS-1000(M)L10	LS-1000(M)L15	LS-1000(M)L20	LS-1000(M)L30	LS-1100(M)L20	LS-1100(M)L30	LS-1100(M)L40
A	4733	5202	5810	7060	6596	7336	9410
B	5923	6392	7010	8260	7276	8016	10090
C	2498	2568	2498	2505	2736	2736	2736
D	2429	2434	2429	2712	2920	2853	2920

\* Specifications are subject to change without notice.

# LS SERIES SPECIFICATIONS

LS-800 series				LS- 800M series			LS-800Y	LS-1000 series	LS-1000M series	LS-1100	
MODLE		A	B	C	MA	MB	MC				
ITEM	Unit	L10/L15/L20/L30	L10/L15/L20/L30	L10/L15/L20/L30	L10/L15/L20/L30	L10 /L15/L20/L30	L10/L15/L20/L30	L20/L30	L10/L15/L20/L30	L10/L15/L20/L30	L20/L30/L40
<b>CAPACITY</b>											
Max. swing	mm	830			830			830	1020	1020	1120
Swing over saddle	mm	660			660			660	780	780	910
Sd. Turning diameter	mm	266(330)			300			300	320	330	440
Max. Turning diameter	mm	760			680			600	900	850	900
Max. Turning length	mm	1100/1600/2100/3100	1095/1595/2095/3095	1050/1550/1950/2950	988/1488/1988/2988	985 /1485/1985/2985	937/1437/1937/2937	1914/2914	1031/1531/2131/3131	970/1470/1970/2970	2114/3014/4464
Bar work capacity	mm	90	105	180	90	105	180	105	180	180	254
<b>TRAVEL</b>											
X Axis travel	mm	390			390			390	500	500	524
Z Axis travel	mm	1150/1650/2150/3150			1150 /1650/2150/3150			2048/3048	1100/1600/2100/3100	1100/1600/2100/3100	2200/3100/4550
Y Axis travel	mm	---	---	---	---	---	---	±80	---	---	---
<b>SPINDLE</b>											
Spindle speed	rpm	2000	2000(1500)	1200	2000	2000(1500)	1200	2000(1500)	1200(1000)	1200(1000)	900
Chuck size		15"	15"(18")	20"	15"	15"(18")	20"	15"(18")	20"(24")	20"(24")	14" (28", 32")
Spindle nose		A2-8	A2-11	A2-15	A2-8	A2-11	A2-15	A2-11	A2-15	A2-15	A2-20
Through hole diameter	mm	102	117	200	102	117	200	117	200	200	275
Bearing diameter	mm	140	160	266	140	160	266	160	266	266	360
<b>TURRET</b>											
Number of tool stations		T10(T12)			T12			T12	T10	T12	T10
Shank height for square tool	mm	32			32			32	32	32	32
Shank diameter for boring bar	mm	50(60)			50			50	65(75)	63	65(75)/(100)
Milling tool shank diameter	mm	---	---	---	---	26	---	26	---	34	---
<b>TAILSTOCK</b>											
Tailstock travel	mm	1000/1500/2000/3000			1000 /1500/2000/3000			2000/3000	1000/1500/2000/3000	1000/1500/2000/3000	2310/3050/4660
Tailstock spindle diameter	mm	125(150)			125(150)			125	180	180	200
Taper hole of tailstock spindle		MT.5(MT.6)			MT.5(MT.6)			MT.5(MT.6)	MT.6	MT.6	MT.6
Tailstock spindle travel	mm	120			120			120	150	150	150
<b>FEEDRATE</b>											
X axis rapid traverse rate	m/min	12			12			12	12	12	12
Z axis rapid traverse rate	m/min	20/16/16/12			20/16/16/12			16/12	16/16/16/12	16/16/16/12	12/10/6
Y axis rapid traverse rate	m/min	---	---	---	---	---	---	6	---	---	---
<b>MOTOR</b>											
Spindle drive motor	Kw	22/26	22/26(30/37)	30/37	22/26	22/26(30/37)	30/37	22/26(30/37)	30/37(37/45)	30/37(37/45)	37/45(45/55)
Turret index motor	Kw	1.2			1.2			1.2	1.2	1.2	---
Milling motor	Kw	---			5.5/7.5(7.5/11)			5.5/7.5(7.5/11)	---	7.5/11	---
X axis drive motor	Kw	4			4			7	4	4	6
Z axis drive motor	Kw	4(7)/4(7)/7/7	4(7)/4(7)/7/7	7/7/7/7	4(7)/4(7)/7/7	4(7)/4(7)/7/7	7/7/7/7	7/7	6	6	6(11)
Y axis drive motor	Kw	---			---			7	---	---	---
<b>MACHINE SIZE</b>											
Height	mm	2402			2402			2762	2498/2568/2498/2505	2498/2568/2498/2505	2736
Width	mm	4538/4968/5658/6700			4538 /4968/5658/6700			5632/6882	4733/5202/5810/7060	4733/5202/5810/7060	6596/7336/9410
Depth	mm	2146			2146			2394/2893	2429/2434/2429/2712	2429/2434/2429/2712	2920/2853/2920
Weight	Kg	10200/11000/13300/14800	10500/11300/13600/15100	11500/12300/14600/16100	10300/11100/13500/15000	10600/ 11400/13700/15200	11600/12400/14700/16200	15500/17000	12000/13500/16500/18000	12000/13500/16500/18000	24000/27000/30000

\* Specifications are subject to change without notice. \* ( ) option

# STANDARD AND OPTIONAL ACCESSORIES

MODEL	LS-800	LS-800M	LS-800Y	LS-1000	LS-1000M	LS-1100
Hi-low Gearbox Spindle	☆	☆	☆	☆	☆	☆
Hydraulic servo turret	☆	☆	☆	☆	☆	☆
Hydraulic tailstock	☆	☆	☆	☆	☆	☆
Automatic PIN actuated tailstock	☆	☆	☆	☆	☆	☆
Boring bar tool holder (4 Pcs)	☆	☆	☆	☆	☆	☆
U-drill tool holder (1 Pcs)	☆	☆	☆	☆	☆	☆
Angle type tool holder (1 Pcs)	☆	☆	☆	☆	☆	☆
OD tool holder (1 Pcs)	-	☆	☆	-	☆	-
X axis live tool holder (1 Pcs)	-	☆	☆	-	☆	-
Z axis live tool holder (1 Pcs)	-	☆	☆	-	☆	-
Boring bar bush 6ø	◆	◆	◆	-	-	-
Boring bar bush 8ø	◆	◆	◆	-	-	-
Boring bar bush 10ø	◆	◆	◆	-	-	-
Boring bar bush 12ø	☆	☆	☆	-	-	-
Boring bar bush 16ø	◆	◆	◆	-	-	-
Boring bar bush 20ø	◆	◆	◆	☆	☆	☆
Boring bar bush 25ø	◆	◆	◆	☆	☆	☆
Boring bar bush 32ø	☆	☆	☆	☆	☆	☆
Boring bar bush 40ø	☆	☆	☆	☆	☆	☆
Boring bar bush 50ø	-	-	-	☆	☆	☆
U-drill bush 16ø	☆	☆	☆	-	-	-
U-drill bush 20ø	☆	☆	☆	-	-	-
U-drill bush 25ø	☆	☆	☆	-	-	-
U-drill bush 32ø	☆	☆	☆	☆	☆	☆
U-drill bush 40ø	☆	☆	☆	☆	☆	☆
U-drill bush 45ø	-	-	-	☆	☆	☆
U-drill bush 50ø	-	-	-	☆	☆	☆
Drill bush MT-1	◆	◆	◆	-	-	-
Drill bush MT-2	◆	◆	◆	-	-	-
Drill bush MT-3	◆	◆	◆	-	-	-
Drill bush MT-4	☆	☆	☆	☆	☆	☆
Drill bush MT-5	-	-	-	☆	☆	☆
Working lamp	☆	☆	-	☆	☆	☆
Tool box	☆	☆	☆	☆	☆	☆
Operation manual	☆	☆	☆	☆	☆	☆
Hydraulic chuck	☆	☆	☆	☆	☆	☆
Foot switch	☆	☆	☆	☆	☆	☆
Chip conveyor	◆	◆	◆	◆	◆	◆
Chip cart	◆	◆	◆	◆	◆	◆
Manual steady rest ø50-350	◆	◆	◆	◆	◆	◆
Hydraulic steady rest SLU3.2(ø50-ø200)	◆	◆	◆	◆	◆	◆
Hydraulic steady rest SLU-4(ø30-ø245)	◆	◆	◆	◆	◆	◆
Hydraulic steady rest SLU-5(ø45-ø310)	◆	◆	◆	◆	◆	◆
Hydraulic steady rest SLU-5.1(ø80-ø350)	◆	◆	◆	◆	◆	◆
Air blow	◆	◆	◆	◆	◆	◆
Auto power off	◆	◆	◆	◆	◆	◆
Parts counter	◆	◆	◆	◆	◆	◆
Automatic front door	◆	◆	◆	◆	◆	◆
Tool setter	◆	◆	◆	◆	◆	◆
3" Boring bar tool holder	-	-	-	◆	-	◆
4" Boring bar tool holder	-	-	-	-	-	◆
High pressure coolant pump system	◆	◆	◆	◆	◆	◆

☆ STANDARD ACCESSORIES ◆ OPTIONAL ACCESSORIES - NO

**TAIWAN TAKISAWA TECHNOLOGY CO., LTD.**

[www.takisawa.com.tw](http://www.takisawa.com.tw)

No. 505, Sec-3, Yeng-Ping Road, Ping-Chen City, Taoyuan Hsien, Taiwan

TEL: +886-3-464-3166 FAX: +886-3-464-3674

E-mail: [callcenter@takisawa.com.tw](mailto:callcenter@takisawa.com.tw)

DISTRIBUTOR

**TAKISAWA**<sup>®</sup>  
TAIWAN



**LS series**

LS-800(M)(Y) / LS-1000(M) / LS-1100

**EXTRA HEAVY DUTY  
CNC LATHE**

