

GENERAL CATALOG



More

www.takisawa.com.tw

Taiwan TAKISAWA Technology Co., Ltd.

No.505, Sec. 3, Yenping Rd., Pingchen Dist.,
Taoyuan City 324, Taiwan.
TEL : +886-3-4643166 FAX : +886-3-4642614

No.89, Sec. 1, Meishi Rd., Yangmei Dist.,
Taoyuan City 326, Taiwan.
TEL : +886-3-4813119 FAX : +886-3-4813185
E-mail : callcenter@takisawa.com.tw

Shanghai TAKISAWA Mechatronics Ltd.

No.1568, Yuanguo Road, Anting Town, Jiading
District, Shanghai
TEL : +86-21-59562955 FAX : +86-21-59562956

TAKISAWA[®]
TAIWAN

Distributor





Taiwan TAKISAWA Technology Co., Ltd. is founded in 1972 with an initial capital of NT\$12 million.

Initially a maker of engine lathes, Taiwan Takisawa has established its technical capabilities through cooperation with Japan Takisawa. This joint effort has laid a solid foundation for the highly skilled professionals as Taiwan Takisawa, who have accumulated years of experience, and can apply world-class manufacturing expertise to achieve the superior product quality that has been acclaimed in the global market.

NEX Series

NEX-1 Series

Feature

- 2 axes
- Belt driven spindle
- Linear guide way



NEX-108M/108Y 110M/110Y

Feature

- C axis, + Y axis
- Belt driven spindle
- Linear guide way



Specifications

	NEX-105	NEX-106	NEX-108	NEX-110
Max. swing	400 mm	350 mm	400 mm	495 mm
Max. turning length	185 mm	350 mm	481 mm	657 mm
Max. turning diameter	220 mm	240 mm	320 mm	400 mm
Max. bar work capacity	42 mm	43 mm	52(65) mm	75(77) mm
Spindle speed	6000 rpm	5000 rpm	4000 rpm	3500 rpm
Chuck size	6"	6"	8"	10"

() : Option

Specifications

	<input checked="" type="checkbox"/> C NEX-108M	<input checked="" type="checkbox"/> Y NEX-108Y	<input checked="" type="checkbox"/> C NEX-110M	<input checked="" type="checkbox"/> Y NEX-110Y
Max. swing	480 mm	480 mm	560 mm	560 mm
Max. turning length	446.8 mm	444.5 mm	629.8 mm	635 mm
Max. turning diameter	260 mm	260 mm	350 mm	350 mm
Max. bar work capacity	52(65) mm	52(65) mm	75 mm	75 mm
Spindle speed	4000 rpm	4000 rpm	3500 rpm	3500 rpm
Chuck size	8"	8"	10"	10"

Y : Y axis C : C axis

NEX Series

NEX-506/906/908

Feature

- Twin spindles
- Built-in spindle
- Linear guide way

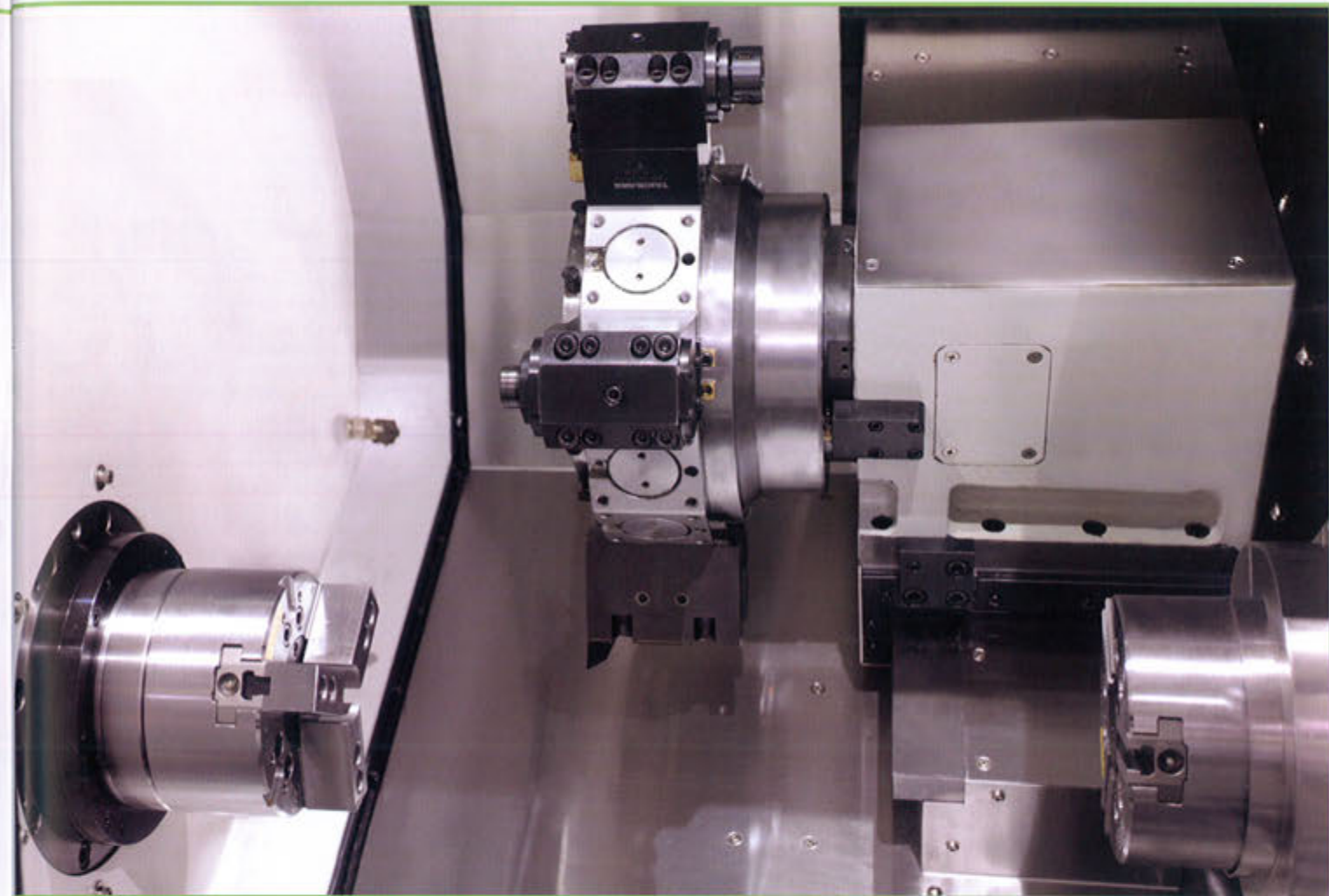

- Twin built-in motor spindles.
- Precisely aligned spindles with speed synchronisation to automate rapid parts transfer between spindles for complex machining.
- Modulized structure with either C axis or both C and Y axes. Every turret position can be fitted with a driven tool for machining flexibility.

Specifications

	☑C	☑Y	☑Y
	NEX-506	NEX-906	NEX-908
Max. swing	600 mm	560 mm	670 mm
Max. turning length	370.4 mm	350 mm	551 mm
Max. turning diameter	290 mm	240 mm	330 mm
Max. bar work capacity	M:52/S:35 mm	M:52/S:35 mm	M:52(65)/S:35(52) mm
Spindle speed	5000 rpm	5000 rpm	5000(4500) rpm
Chuck size	6"	6"	M:8"/S:6"

☑C : C axis ☑Y : Y axis () : Option M : Main spindle S : Sub spindle

Travel & Feedrate

	NEX-506	NEX-906	NEX-908
X axis travel	185 mm	160 mm	220 mm
X axis rapid traverse rate	20 m/min	20 m/min	20 m/min
Z axis travel	420 mm	425 mm	630 mm
Z axis rapid traverse rate	24 m/min	24 m/min	24 m/min
Y axis travel	-- mm	±40 mm	±50 mm
Y axis rapid traverse rate	-- m/min	10 m/min	10 m/min
B axis travel	485 mm	485 mm	710 mm
B axis rapid traverse rate	20 m/min	20 m/min	20 m/min

LA Series

LA-150/200 Series

Feature

- 2 axes, + C axis
- Belt driven spindle
- Box guide way



Specifications

	LA-150[L]	LA-150M[L] <input checked="" type="checkbox"/> C
Max. swing	470 mm	470 mm
Max. turning length	329[629] mm	313[612] mm
Max. turning diameter	T8:250/T12:320 mm	250 mm
Max. bar work capacity	42 mm	42 mm
Spindle speed	5000 rpm	5000 rpm
Chuck size	6"	6"

C : C axis

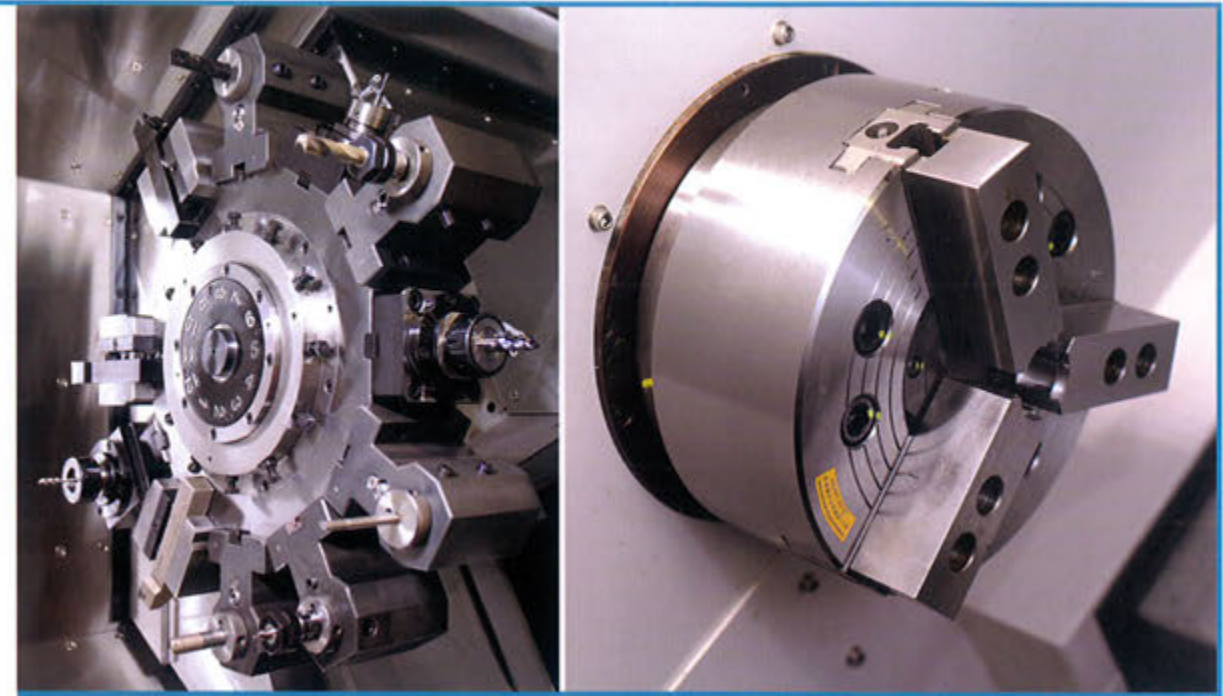

Specifications

	LA-200[L]	LA-200M[L] <input checked="" type="checkbox"/> C
Max. swing	470 mm	470 mm
Max. turning length	300[600] mm	284[584] mm
Max. turning diameter	T8:250/T12:320 mm	250 mm
Max. bar work capacity	52 mm	52 mm
Spindle speed	4000 rpm	4000 rpm
Chuck size	8"	8"

C : C axis

LA Series

LA-250/300 Series

Feature

- 2 axes, + C axis, + Y axis
- Gear box spindle
- Box guide way



[Rotating tail stock]

High thrust and clamping forces provide maximum stability especially when working with long workpieces.

The heavy duty one-piece slant bed machine base is an extremely rigid structure and together with its heavy duty box way design promotes the highest machining accuracy.

Its design also allows ample space for chip flow and easy clearance of debris away from the machining process.

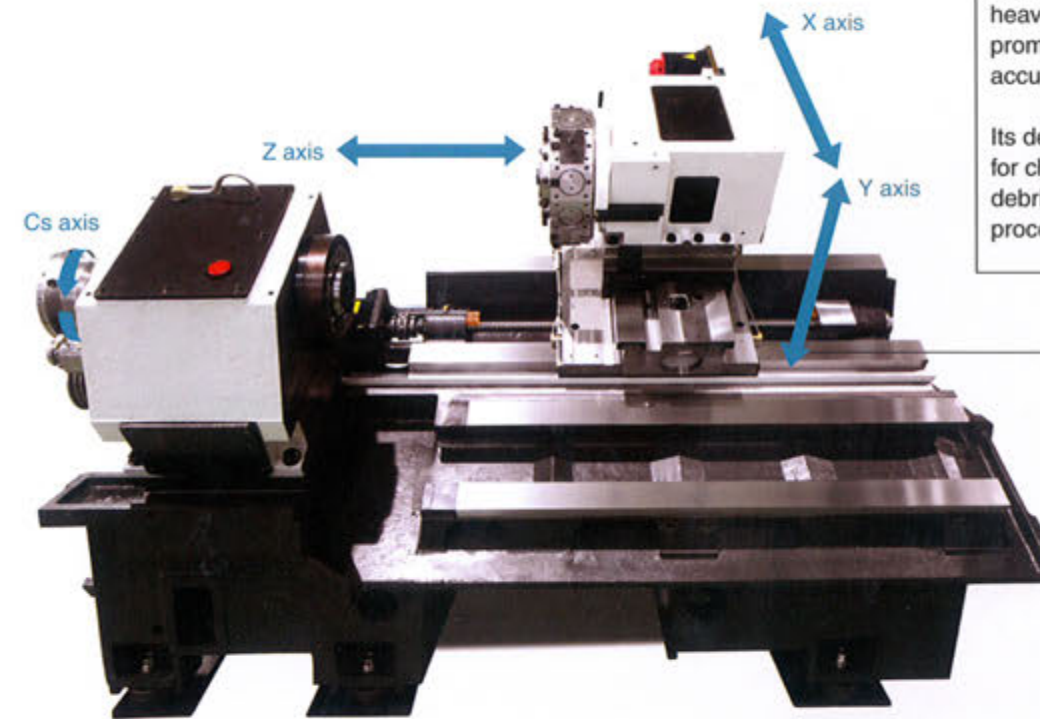

Specifications

	LA-250[L]	LA-250M[L] <input checked="" type="checkbox"/> C	LA-250Y[L] <input checked="" type="checkbox"/> Y	LA-300
Max. swing	580 mm	580 mm	580 mm	580 mm
Max. turning length	765[1165] mm	733.5[1133.5] mm	746.5[1146.5] mm	1086.9 mm
Max. turning diameter	450 mm	420 mm	350 mm	450 mm
Max. bar work capacity	67(90) mm	75 mm	75 mm	90 mm
Spindle speed	3500 rpm	3500 rpm	3500 rpm	3000 rpm
Chuck size	10"	10"	10"	12"(15")

Y : Y axis C : C axis () : Option

LA Series

LA-350/450 Series

Feature

- 2 axes, + C axis
- Gear box spindle
- Box guide way



Max. turning length 800~2240mm

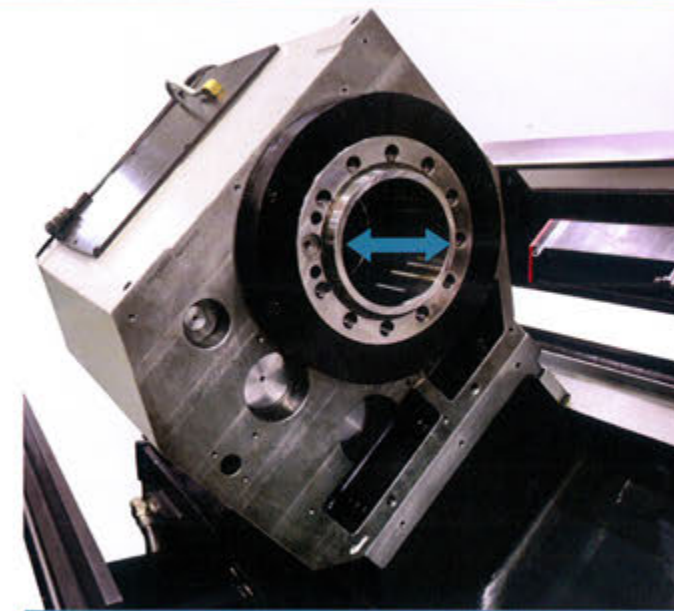

LA-350(M) through hole diameter : 126mm
LA-450 through hole diameter : 162mm

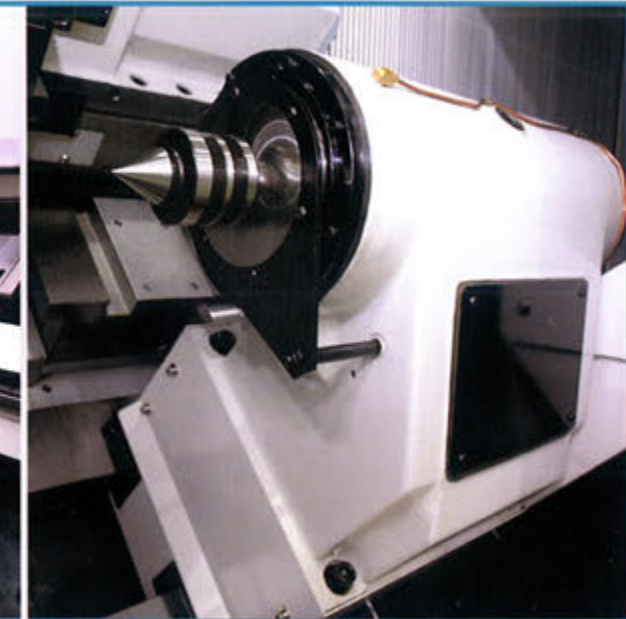

Hydraulic tailstock increase in the processing of long boring bar, can show high precision quality.

Specifications

	LA-350_L8/L16/L22	LA-350M_L8/L16/L22 <input checked="" type="checkbox"/> C
Max. swing	780 mm	780 mm
Max. turning length	800/1600/2240 mm	681/1481/2121 mm
Max. turning diameter	550 mm	480 mm
Max. bar work capacity	115 mm	115 mm
Spindle speed	2500(2000) rpm	2500(2000) rpm
Chuck size	12"(15")	12"(15")

C : C axis () : Option

	LA-450_L8/L16/L22	LA-450M_L8/L16/L22 <input checked="" type="checkbox"/> C
Max. swing	780 mm	780 mm
Max. turning length	780/1580/2220 mm	662/1462/2102 mm
Max. turning diameter	550 mm	480 mm
Max. bar work capacity	150 mm	150 mm
Spindle speed	1800(1500) rpm	1800(1500) rpm
Chuck size	18"(20")	18"(20")

C : C axis () : Option

※ Specifications are subject to change without notice.

LA Series

LA-250YS

Feature

- Twin spindles
- 2 axes,+ C axis,+ Y axis
- Built-in spindle
- Box guide way

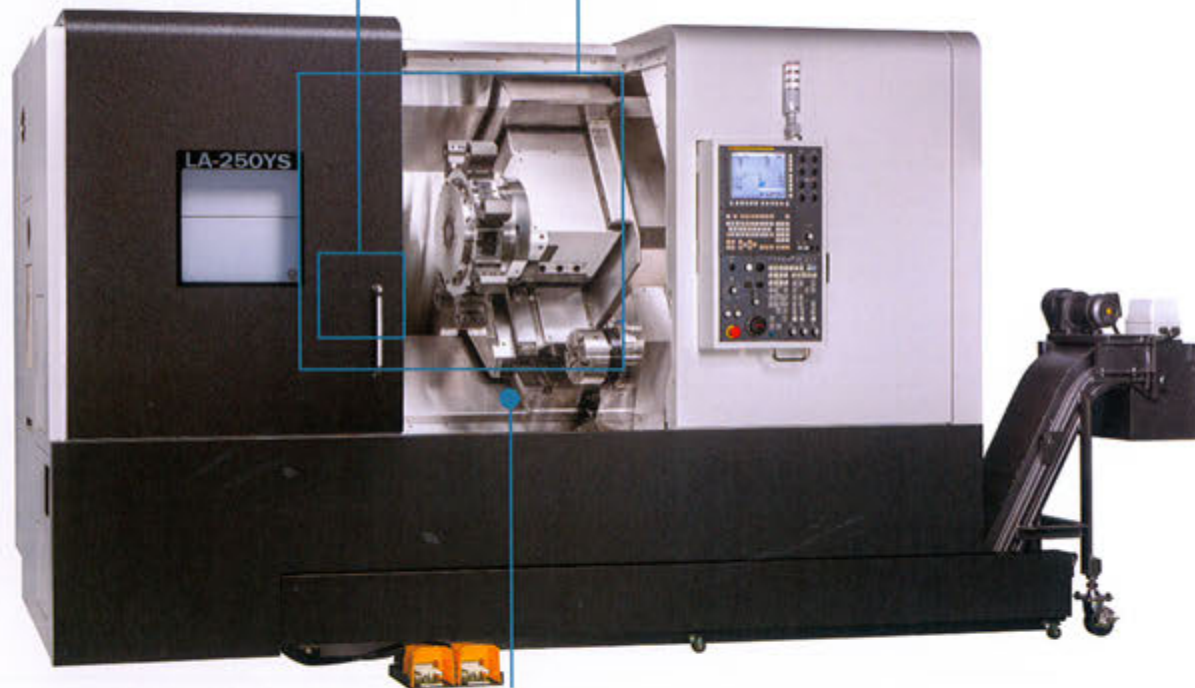
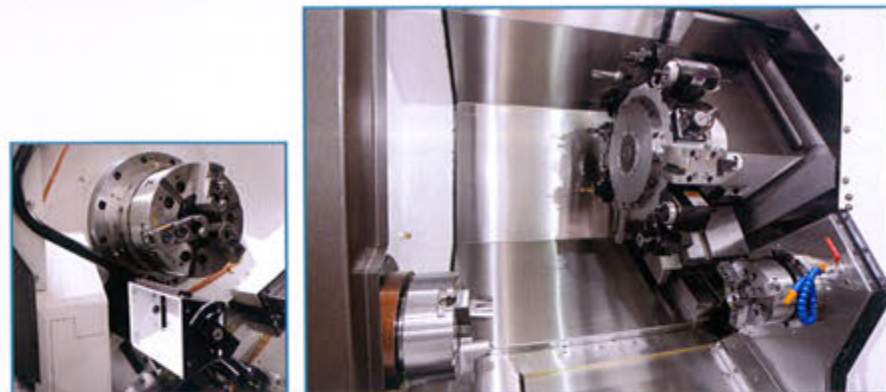

Spec. Internal use of stainless steel sheet , texture upgrade !

LA-250YT

Feature

- Servo tailstock
- 2 axes,+ C axis,+ Y axis
- Built-in spindle
- Box guide way

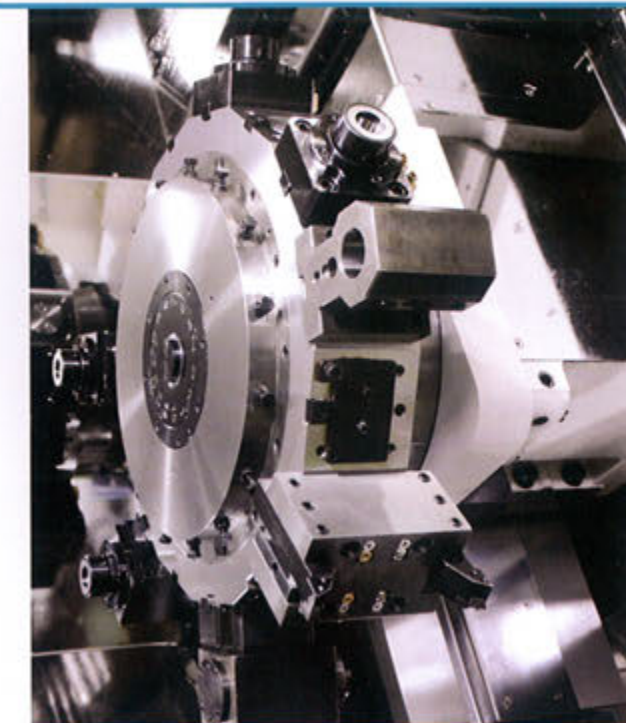

T15 turret



Specifications

	LA-250YS <input checked="" type="checkbox"/> Y	LA-250YT <input checked="" type="checkbox"/> Y
Max. swing	600 mm	600 mm
Max. turning length	737 mm	737 mm
Max. turning diameter	370 mm	370 mm
Max. bar work capacity	M:75/S:52 mm	75(81) mm
Spindle speed	3500 rpm	3500 rpm
Chuck size	M:10"/S:8"	10"
Y axis travel	+65-50 mm	+65-50 mm

Y : Y axis () : Option M : Main spindle S : Sub spindle

※ Specifications are subject to change without notice.

EX Series

Feature

- C axis
- Built-in spindle
- Linear guide way

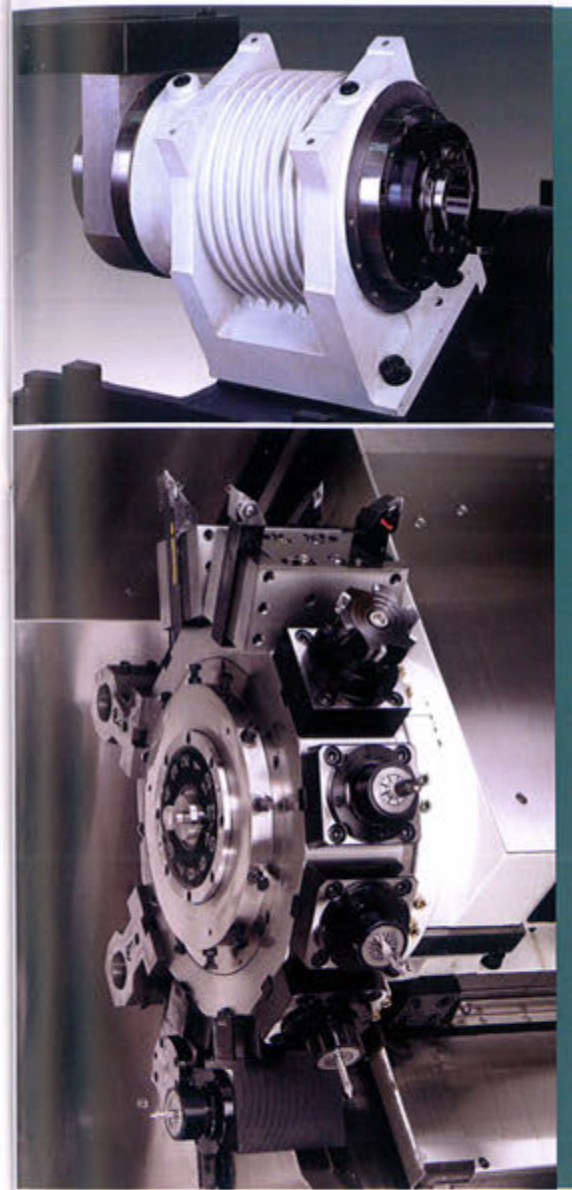

Specifications

	<input checked="" type="checkbox"/> C	<input checked="" type="checkbox"/> C	<input checked="" type="checkbox"/> C	<input checked="" type="checkbox"/> C
	EX-308	EX-310	EX-508	EX-510
Max. swing	400 mm	495 mm	445 mm	540 mm
Max. turning length	530 mm	710 mm	380 mm	509 mm
Max. turning diameter	260 mm	350 mm	300 mm	380 mm
Max. bar work capacity	55 mm	75(77) mm	M:52/S:35 mm	M:75/S:52 mm
Spindle speed	4000 rpm	3500 rpm	4000 rpm	3500 rpm
Chuck size	8"	10"	8"	10"

C : C axis () : Option M : Main spindle S : Sub spindle

Specifications

	<input checked="" type="checkbox"/> Y	<input checked="" type="checkbox"/> Y	
	EX-710	EX-910	
Max. swing	680 mm	680 mm	Single spindle : EX-308 EX-310
Max. turning length	660 mm	660 mm	Twin spindles : EX-508 EX-510
Max. turning diameter	340 mm	340 mm	Y axis : EX-710
Max. bar work capacity	75 mm	M:75/S:52 mm	Twin spindles + Y axis : EX-910
Spindle speed	3500 rpm	3500 rpm	
Chuck size	10"	10"	

Y : Y axis M : Main spindle S : Sub spindle

FX Series

Feature

- Twin spindles & turrets
- Built-in spindle
- X & Y axis box guide way (FX-800)



Upper turret(T16)

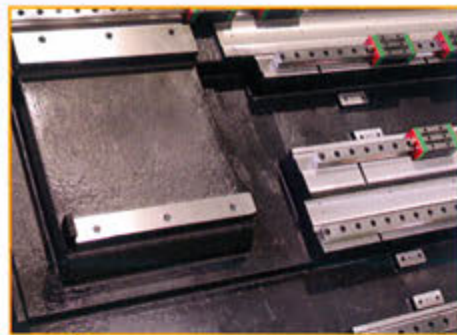

The bed with superior rigidity

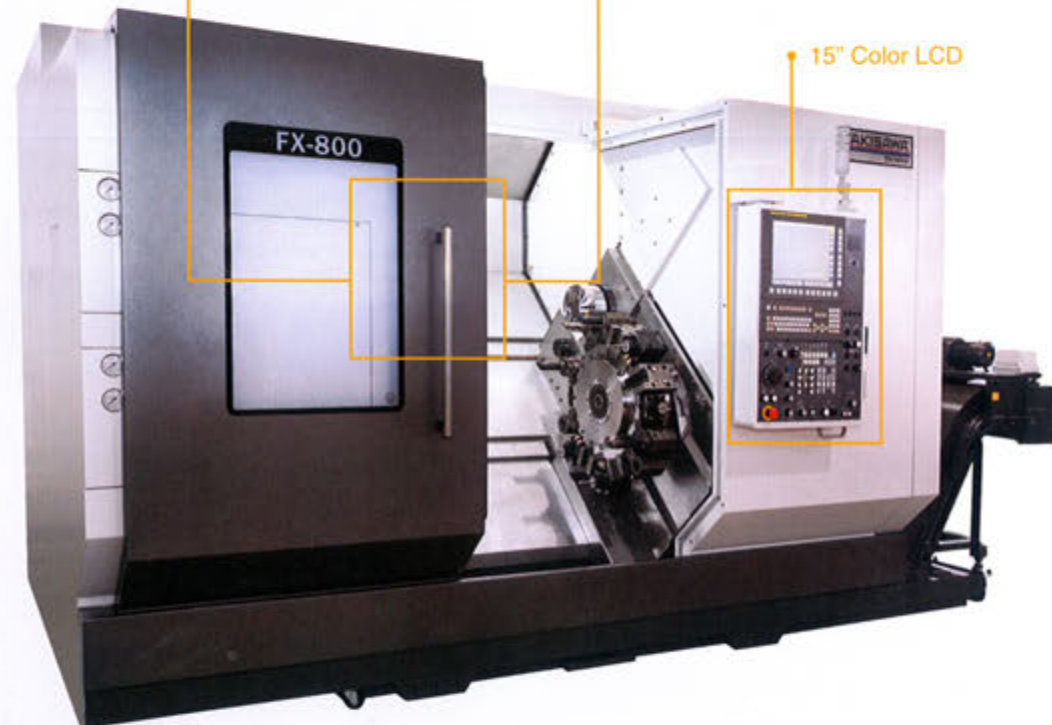

15" Color LCD



Specifications

	FX-600	FX-800
Max. turning length	510 mm	657 mm
Max. turning diameter	300 mm	260 mm
Max. bar work capacity	M:42/S:42 mm	M:65/S:52 mm
Spindle speed	6000 rpm	M:4500/S:5000 rpm
Chuck size	6"	M:8"/S:8"

☑ Y : Y axis M : Main spindle S : Sub spindle

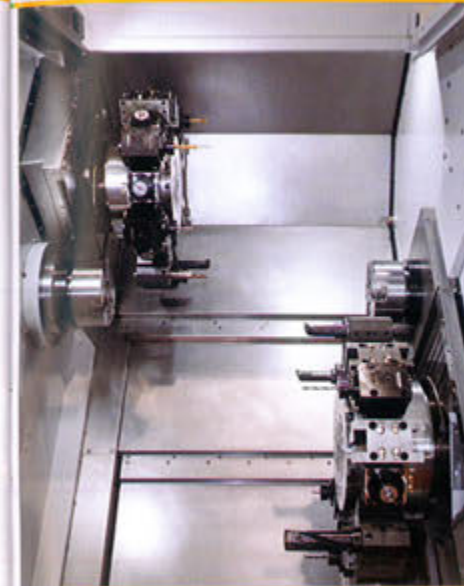

T16(FX-800)

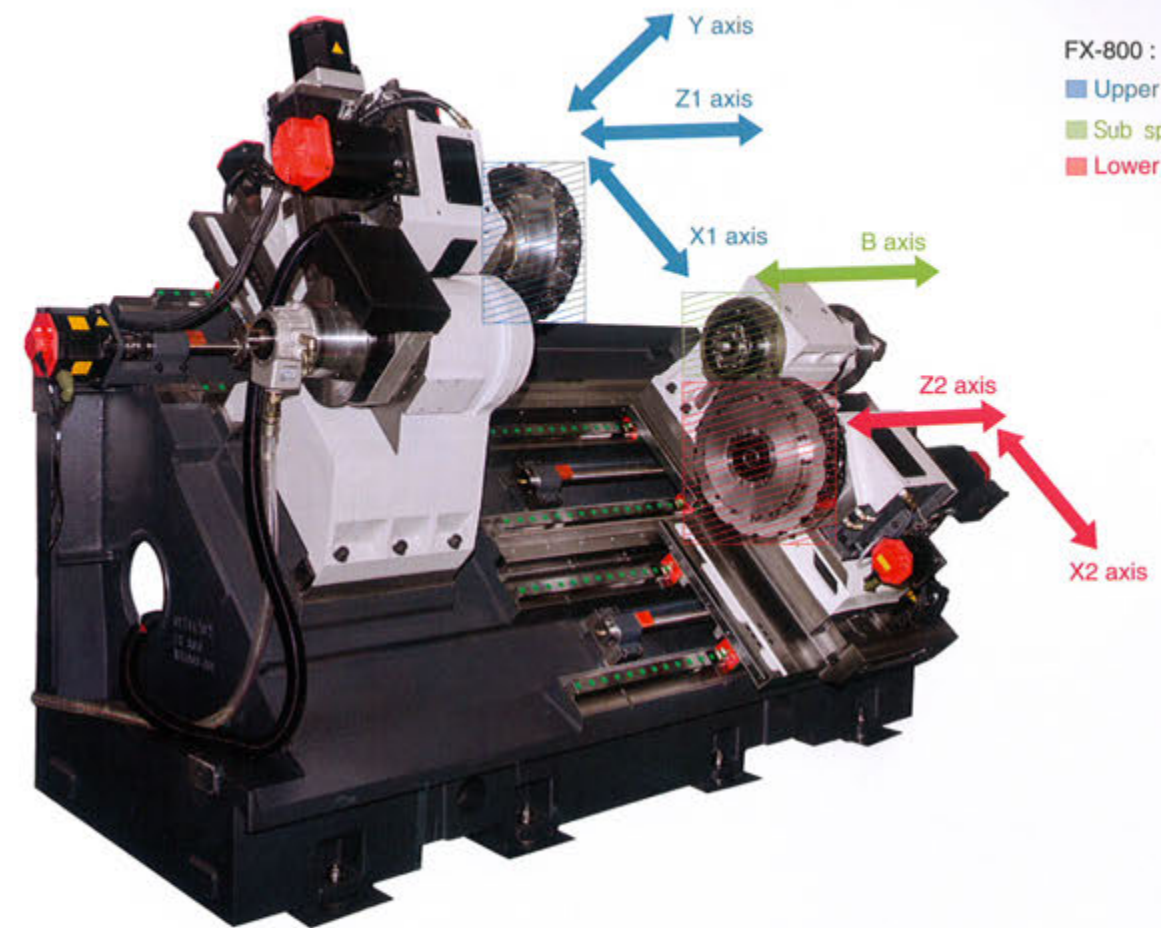

FX-800 :
■ Upper turret
■ Sub spindle
■ Lower turret



Travel & Feedrate

	FX-600	FX-800
X1/X2 axis travel	180/180 mm	215/215 mm
X1/X2 axis rapid traverse rate	24/24 m/min	20/20 m/min
Z1/Z2 axis travel	540/540 mm	750/745 mm
Z1/Z2 axis rapid traverse rate	40/40 m/min	20/20 m/min
Y axis travel	±35 mm	±50 mm
Y axis rapid traverse rate	16 m/min	10 m/min
B axis travel	620 mm	800 mm
B axis rapid traverse rate	40 m/min	20 m/min

※ Specifications are subject to change without notice.

LS Series

Feature

- Extra heavy duty CNC
- 2 axes,+ C axis,+ Y axis
- Gear box spindle
- Box guide way

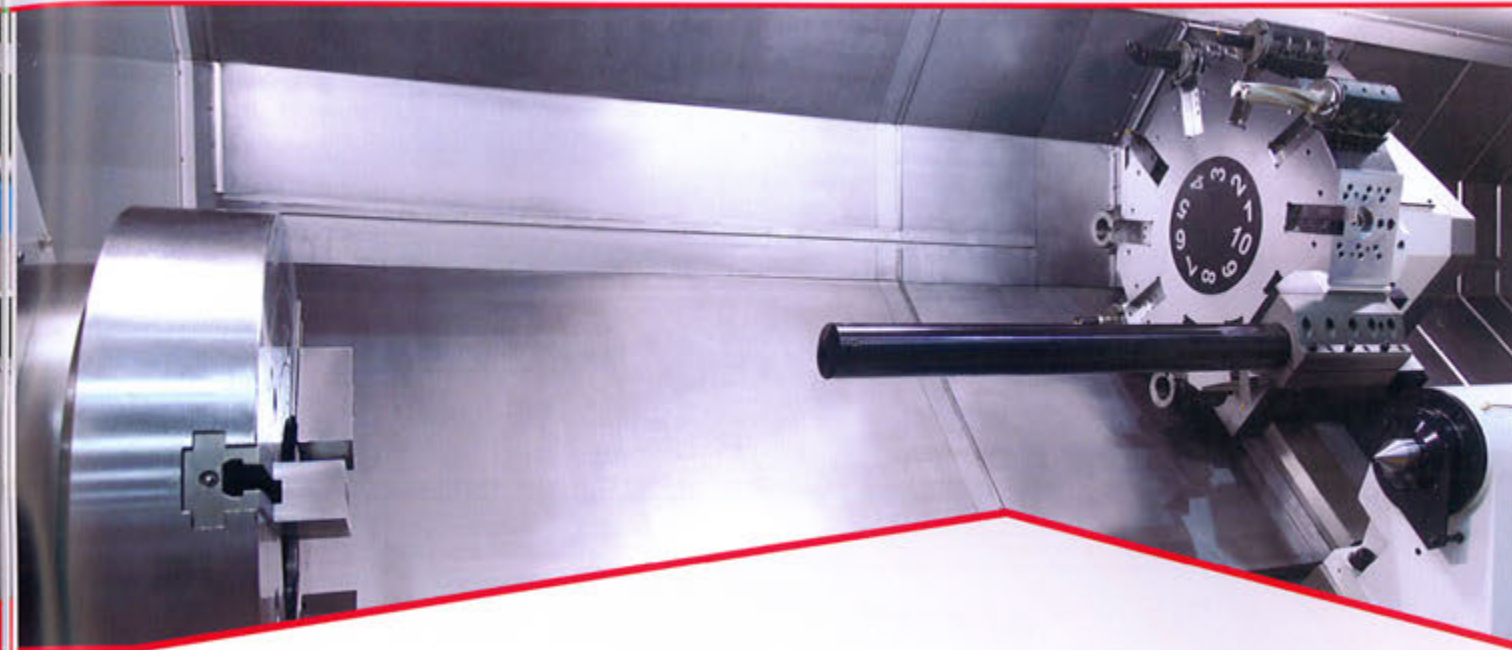
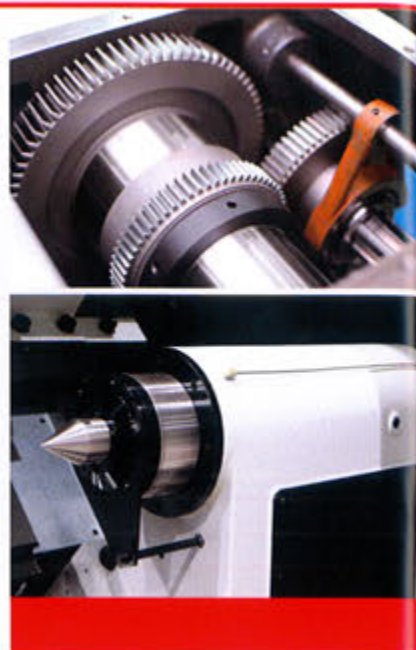

Specifications

	LS-800_A/B/C	LS-800M_MA/MB/MC <input checked="" type="checkbox"/> C	LS-800Y <input checked="" type="checkbox"/> Y
Max. swing	830 mm	830 mm	830 mm
Max. turning diameter	760 mm	680 mm	600 mm
Max. bar work capacity	90/105/180 mm	90/105/180 mm	105 mm
Spindle speed	2000/1500/1200 rpm	2000/1500/1200 rpm	2000 rpm
Chuck size	15"/18"/20"	15"/18"/20"	15"

	LS-1000	LS-1000M <input checked="" type="checkbox"/> C	LS-1100
Max. swing	1020 mm	1120 mm	1120 mm
Max. turning diameter	900 mm	850 mm	900 mm
Max. bar work capacity	180 mm	180 mm	254 mm
Spindle speed	1200(1000) rpm	1200(1000) rpm	900 rpm
Chuck size	20"(24")	20"(24")	24"(28",32")

Y : Y axis C : C axis () : Option

Max. turning length

Unit : mm

LS-800_A[L10/L15/L20/L30]	1100/1600/2100/3100
LS-800_B[L10/L15/L20/L30]	1095/1595/2095/3095
LS-800_C[L10/L15/L20/L30]	1050/1550/1950/2950
LS-800M_MA[L10/L15/L20/L30]	988/1488/1988/2988
LS-800M_MB[L10/L15/L20/L30]	985/1485/1985/2985
LS-800M_MC[L10/L15/L20/L30]	937/1437/1937/2937
LS-800Y_L10/L20/L30	925/1915 /2915
LS-1000_L10/L15/L20/L30	1031/1531/2131/3031
LS-1000M_L10/L15/L20/L30	970/1470/1970/2970
LS-1100_L20/L30/L40	2114/3014/4464



VTL Series

Feature

- CNC vertical lathe
- 2 axes,+ C axis
- Gear box spindle

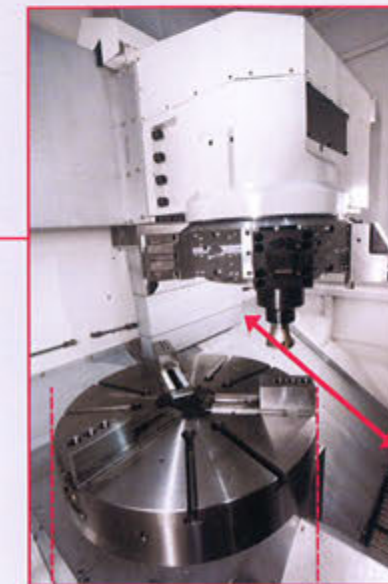
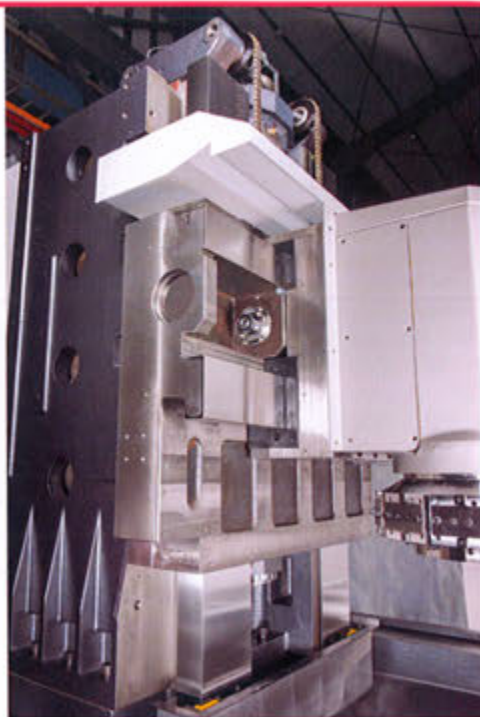

Chuck size : 32"
(OP : 40")



Specifications

	VTL-350	VTL-450	VTL-450M <input checked="" type="checkbox"/> C
Max. swing	600 mm	600 mm	600 mm
Max. turning length	416 mm	415 mm	381 mm
Max. turning diameter	460 mm	460 mm	460 mm
Spindle speed	2500 rpm	2500 rpm	2500 rpm
Chuck size	12"(15"/18")	12"(15"/18")	12"(15"/18")

C : C axis () : Option

Specifications

	VTL-750	VTL-750M <input checked="" type="checkbox"/> C	VTL-750A	VTL-1100	VTL-1100M <input checked="" type="checkbox"/> C
Max. swing	800 mm	800 mm	1050 mm	1330 mm	1330 mm
Max. turning length	717.5 mm	654.5 mm	775 mm	1000 mm	1000 mm
Max. turning diameter	750 mm	730 mm	1050 mm	1200 mm	1200 mm
Spindle speed	2000 rpm	2000 rpm	1500 rpm	850 rpm	850 rpm
Chuck size	15"(18"/21"/24")	15"(18"/21"/24")	24"(32")	32"(40")	32"(40")

C : C axis () : Option 22